

THE CALORIC POWER OF WOODEN BIOMASS

Aurel LUNGULEASA¹

Abstract: *The paper presents some aspects referring to caloric power determination of some kinds of wooden biomasses, installations and methodology for determining. The superior, the net or inferior caloric power, differences, importance and principles of determination are the main aspects tackled in this paper. The comparison between some types of caloric power for different kinds of wooden wastes is also presented.*

Key words: *inferior caloric power, wooden biomass, calorimeter, caloric bomb.*

1. Introduction

Wood biomass represents a renewable source of energy. It does not contribute to the issue of changing the environment because it recycles the carbon dioxide from the atmosphere. The final result of burning wood biomass is expressed through the caloric power, a notion through which we can understand the heat obtained by burning a mass unit. The caloric power of wood is determined on the same way as for other solid fuels such as coals and it represents the quantity of heat resulted when burning the fuel's mass unit. Before this attempt, the wood fuel is brought to a temperature of 20 °C. Generally, for fuel materials with great percentage of water and hydrogen, as the wood biomass, there are two types of caloric power of these solid fuels according to the status of water from the burning products, respectively the superior caloric power (when the water steams have condensed, releasing the evaporation heat) and the inferior caloric power (when the water is among the burning gases as water steams; in this case, some of the heat released is consumed to

vaporize this form of water). The superior caloric power is the total heat quantity resulted from a perfect combustion of 1 kg of fuel. The inferior caloric power is the difference between the superior caloric power and the quantity of heat used to vaporize water from burning gases. The superior caloric power is determined using the calorimetric bomb, where the water steams formed through hydrogen combustion (including here the hydrogen formed through the decomposition of water) condensate inside the bomb recipient, releasing about 600 kcal per each kilogram of water condensed steams (the so-called condensing heat). Practically, the superior caloric power cannot be effectively used because the water steams are evacuated outside and so the inferior caloric power remains the most important [2].

2. The Methodic and Equipments

The determination principle and the working method depend on the equipment used respectively, if liquid calorimeters or calorimetric bombs (with exploding burning) are used. The determination of wood's

¹ Dept. of Wood Technology, *Transilvania* University of Braşov.

caloric power using a liquid calorimeter is based on a volume increase of a calorimetric liquid that has a high dilatation factor as a result of the heat received when burning a precise quantity of fuel material. In these conditions, the volume increase of the calorimetric liquid indirectly represents the caloric power for this kind of fuel.

As for the calorimetric bomb, the caloric power of wood is determined by measuring the temperature difference of a certain quantity of water that cools the calorimetric bomb. This way, it is possible to determine the quantity of heat released by a mass unit of the solid fuel that has been analyzed; finally, this value represents the fuel's caloric power.

The installation used to determine the caloric power of wood (see Figure 1) has many components, respectively: the proper calorimeter (or the calorimetric bomb), the pressure decelerator, the oxygen tube, the micro-briquetting press, the ignition device connected to the electrical system, electronic balance, volumetric flasks, the mixing device with propeller, distilled water or calorimetric liquid etc. It is best firstly to prepare individually each of the installation's components (especially the calorimetric bomb), afterwards the connections are done and the installation is started by closing the electric circuit using a switcher. From this moment, the mixer automatically starts and it homogenizes the water temperature from the calorimetric container.

The determination starts in the moment when the temperature of elements inside the calorimetric container is uniform and has three stages:

- the initial stage, which has as purpose determining water temperature variations inside the calorimetric container, due to heat changing with exterior before burning. In this period of time, usually up to 5 minutes, the temperature is recorded by a precise thermometer. The last temperature from the initial stage actually represents

the first temperature from the second stage. At the end of the initial stage, the switcher is pressed, determining the ignition of the fuel probe;

- the main stage has as purpose determining the water temperature increase in the calorimetric container, caused by the burning of the wood particle. To determine the final temperature, the values recorded are being read every minute. The final temperature is given by the maximum value of the temperature because after the temperature starts to drop it means that it doesn't receive any more heat from the calorimetric bomb;

- the final stage has as purpose calculating the average water temperature variation in the calorimetric container, because of the heat exchange with the exterior, after the burning took place. The same as in the first stage, the temperature recorded by a thermometer is read from one minute to another.

After this test is over, the calorimetric bomb is pulled out from the calorimetric container (after the gases have been evacuated and the bomb has been depressurized), further research is done to see if there had been a complete burning (by studying the ash obtained after the combustion). Also it has to be determined if all quantity of nickel-plated wire had been burned. The caloric power is determined using the following ratio [5]:

$$Q_s = \frac{k(t_f - t_i + t_c) - q_s}{m} \text{ [kcal/kg]}, \quad (1)$$

where: k - calorimetric factor; t_f - the final temperature value; t_i - the initial temperature value; t_c - temperature of combustible biomass; q_s - the heat consumed to burn the wire; m - the mass of the wood pellets.

This caloric power (see relation 1, where Q_s is determined) can be considered to be the superior caloric power that has been calculated with great approximation. To

obtain the exact caloric power, the following aspects have to be kept in mind:

- the quantity of heat released through the transformation of sulfur dioxide (resulted in burning processes) into sulfuric acid (dissolved in the water inside the bomb) is subtracted from the total obtained quantity;
- the sulfur content from the analyzed sample;
- the heat correction needed to form nitric acid is subscribed from the total heat.

The inferior caloric power (Q_i) of wood can be calculated with the following ratio:

$$Q_i = Q_s - 6(U + 9h) \text{ [kcal/kg]}, \quad (2)$$

where: U - the wood sample's moisture content, expressed in %; h - the wood sample's hydrogen content expressed in %.

After an elaborated preparation of each of the calorimeter components, one can proceed to installing the device and using it. The calorimetric bomb is introduced inside the calorimetric container. The mixer and the cowl are then fixed. The electric installation's circuit is then closed so as to activate the mixer in order to make a uniform homogenization of the temperature.

The calorimetric bomb or the proper calorimeter is the main component of the installation used to determine the wood caloric power and it is made out several components (as it can be observed in Figure 1), respectively: cylindrical carcass, cowl; admission tube for oxygen; skillet for shock protection.

The calorimetric bomb (Figure 1). It is a container made out of special steel that is inert to acids resulted through burning; this is filled with oxygen at a pressure of 25-30 atm. From a metrological point of view, the caloric bomb has to resist at pneumatic pressures up to 50 atmospheres and at a hydraulic pressure of 200 atm., therefore resisting at the great pressures created when burning the researched fuel. The cowl is

equipped with a rubber fitting to ensure a perfect enclosure. The cowl has three openings. Opening 4 is used to introduce pressurized oxygen; a metallic pipe goes in from the exterior through this opening and it is used as electrode to light the fuel. Opening 5 is used to evacuate the burning product. The second electrode gets inside through opening 6 and it is isolated towards the bomb's mass. The solid fuel is gathered in a nickel-plated spiral which has its endings connected to electrodes. The nickel-plated spiral is chosen to be as convenient as possible, having 0.5 mm in diameter so as to become incandescent when the electricity passes through, thus lighting the fuel.

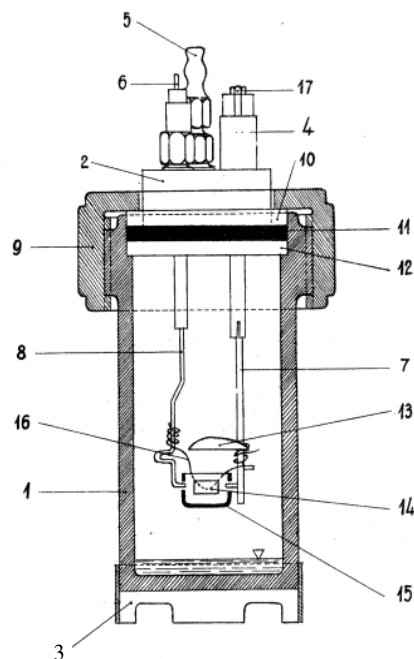

Fig. 1. *The calorimetric bomb:*
 1 - cylindrical carcass; 2 - cowl; 3 - ring-like support with three legs; 4 - oxygen admission shutter; 5 - shutter for evacuating burned gases; 6 - electrode; 7 - connection tube; 8 - draw bar; 9 - anchorage ferrule; 10 - metallic fitting; 11 - rubber fitting; 12 - the cowl's articulated rib; 13 - protection shield; 14 - fuel button; 15 - skillet

The calorimetric bomb's carcass (1) is made out of resistant stainless steel which cannot be attacked by acids and corroded. The cowl 2 has 2 valves 4 and 5 and an electrode 6. Through the valve 4 which communicates with tube 7, the pressurized oxygen is introduced into the calorimetric bomb. Through the valve 5 the burning gases from the calorimetric bomb are evacuated at the end of experiment. On tube 7 there is placed a safety screen 13 which does not allow the flame to reach the bomb's cowl. The skillet 15 has a protection purpose and can be made out of quartz, porcelain or other material.

Necessary accessories

The necessary accessories for making determination are the following ones:

- the analytic balance for weighting the fuel sample, that has a top measuring accuracy of 0.0002 g;

- the oxygen tube, with a pressure redactor equipped with manometers; one of the manometers shows the pressure inside the oxygen tube and the other is assembled after the reduction valve has indicated the oxygen pressure inside the calorimetric bomb;

- two volumetric flasks, one of 2000 cm³, the other of 1000 cm³ for measuring the water quantities introduced inside the calorimeter;

- the wire for lighting the fuel sample, made out of soft steel, nickel, silver, platinum and which has a width of approx. 0.1 mm and a cotton wire which sustains the burning.

When there is no explosive burning, the liquid-dilatation calorimeter is used; in this case the installation used to determine the caloric power is simpler than the one using the calorimetric bomb. Using the calorimetric bomb, the superior caloric power Q_s is determined, in the premise of a complete burning and an oxygenic atmosphere, at approximately 25 bars and

also the inferior caloric power Q_i can be deduced through calculus, after analyzing the water present inside the fuel. Using the calorimetric bomb, the quantity of heat obtained when burning a known mass of fuel that has previously been very precisely weighted can be determined.

3. The Experiment

First, the fuel that has to be researched is weighted (a fuel button that has maximum weight of 1 kg). The fuel is wrapped, or penetrated by a nickel-plated spiral (or made out of electrolytic soft iron), which has its endings connected to the electrodes that are placed on the calorimetric bomb's cowl. After the cowl is screwed on, the bomb is connected with an oxygen tube. The evacuation valve is left opened and the oxygen tube is turned on until the manometer, connected to the oxygen tube, indicates a post-decelerator pressure of 22-30 atm. This will also be the pressure inside the bomb. Being prepared this way, the bomb is introduced inside the calorimeter, where it has to get 2000-2500 cm³ of water that has a temperature with 2 °C higher than the ambient environment's one:

- the calorimetric bomb is introduced inside the calorimetric reservoir, sealing the bomb (in no circumstances gas bubbles should appear on the surface);

- the connection with the electric circuit is made, without pressing the ignition button;

- the mixer is installed so that when it moves, it doesn't make contact with the bomb or the calorimeter's walls;

- the Beckmann thermometer is introduced in the water from the calorimeter;

- the thermostat is covered with its cowl and the temperature' sight glass is turned on from the draw bar so that the thermometer's scale marks are clear.

The initial stage

The Beckmann thermometer is read at

temperature t_0 at a certain moment, then further indications are read each minute for 5 minutes and the indicated temperature t_i is written down. This stage is necessary to calculate the heat lost at the calorimeter's exterior.

The main stage

After reading the last temperature t_i from the initial stage, the ignition button is pressed. Then one must keep track of the temperature increase until it reaches the maximum value. We mark this value with t_f and the time period (in minutes) from ignition until the temperature t_f has been reached. The indications are also read from minute to minute and written down in a table.

The final stage

After the maximum temperature has been reached, a fact that can be observed through a constant or decreasing temperature, further temperature readings are written each minute, for another five minutes. This stage together with the preliminary one is necessary to calculate the quantity of heat lost outside the calorimeter.

The evacuation shutter is opened and the burned gases are carefully evacuated. If the

burning is complete, then one must determine the waste quantity by weighting it and determine the sulfur from the bomb.

4. Processing Experimental Data

The water's equivalent value for the calorimeter will be the average of 5 consecutive determinations on condition that the differences between the values of these determinations would not be higher than 10 grams. First influence of caloric power is moisture content of wooden pieces and is showed in Figure 2, for superior and inferior caloric power.

It is normal that the caloric power of wooden biomass to decrease with the increase of moisture content because of great amounts of water steams which are eliminated from wood. The caloric power and the humidity content have a linear dependency.

For the wet fuel, a part of the fuel's energy is used to boost up the temperature and another part is consumed to vaporize water. Other influences can be seen in Figure 3 such as group of wood (softwood and hardwood) and even chemical resin. Volatile substances from wood accelerate the wood burning and consequently increase caloric power of wood [3].

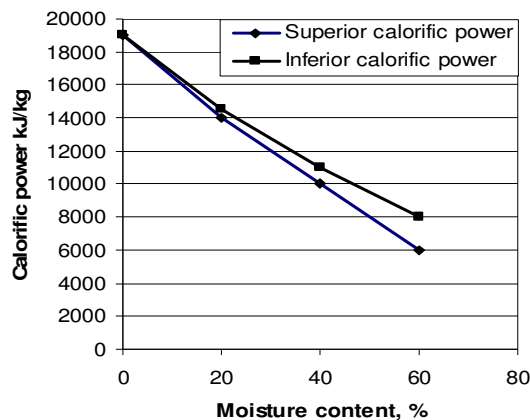

Fig. 2. Influence of moisture content upon caloric power

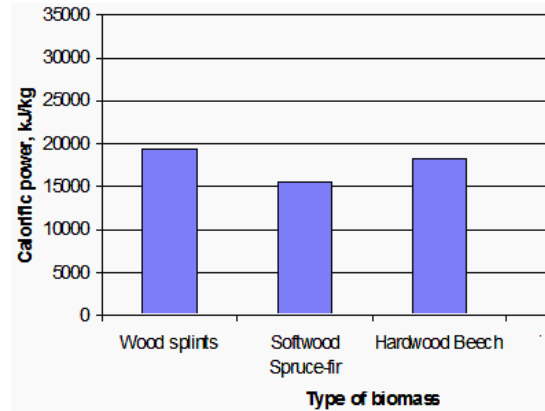

Fig. 3. *The caloric power for different types of biomass*

5. Final Conclusions

The caloric power of different types of biomass shows the total quantity of heat resulted in time of burning. The simple sawdust has a very low energetic power. By briquetting and admixing lignin remains from paper factories and cellulose factories [1], [4] the caloric power will increase very much. At the same time, the use of briquettes makes transporting and also the fueling of burners easier. The caloric power depends very much on the moisture content of wood and that is the main result of experiments. Also, the chemical resins which are often found in wood joints and frames as waste, have a great caloric power, but also release a greater amount of exhaust gases into the atmosphere. Therefore the use of dried wooden materials or wooden waste (sawdust, chips and dust) in the form of briquettes and pellets is recommended.

References

1. Gavrilesu, D.: *Energy from Biomass in Pulp and Paper Mills*. In: *Environmental Engineering and Management Journal* **5** (2008), p. 537-546.
2. Lunguleasa, A., Panayotov, P.: *Brichete ecologice obținute din biomasă lemnoasă (Ecological Briquettes from Wooden Biomass)*. In: *Recent* **1** (2008) No. 22, p. 51-54.
3. Sjostrom, E.: *Wood Chemistry*. Helsinki. Academic Press, 2006.
4. Steuner, A.: *Developments in Timber Engineering. The Swise Contribution*. Birkhauser Print House, 2006.
5. Teuch, O., Hofeanuer, A., Troger, F., From, J.: *Basic Properties of Specific Wood Based Materials Carbonised in a Nitrogen Atmosphere*. In: *Wood Science and Technology*, Springer **38** (2004) No. 3, p. 54-57.