

THE WELD ALUMINOTHERMIC OPTIMIZATION OF RAIL TRACK BY MICROALLOYED

D. M. COSTEA¹ M. N. GĂMAN² G. DUMITRU³

Abstract: *The welding railway rails can be made by aluminothermic welding process. This process is used throughout the worldwide because of the low cost. As a result of the aluminothermic reaction results in a thermic the steel should have mechanical properties similar to those of the rails. This paper presents microalloying steel thermic effects with modifier complex of $FeSi_{34}V_{25}Ti_{12}$ and FeB_{15} , from the point of view of mechanical tests.*

Key words: *steel thermic microalloying, aluminothermic reaction, rails welded*

1. Introduction

The aluminothermic welding steel is cast thermic over the ends of the rails which have to be welded, placed in a particular recess, the joining of two half dies made of refractory. The reaction which lies behind this method is the reaction of the aluminothermic welding. The thermic steel is a stainless made by reaction aluminothermic, using a mixture of metal powders, called thermite. The thermite mixture is granulated iron oxide, aluminum and ferro-alloys for alloying. The thermic steel, casting, has about 25000C, is fluid and fills the cavity available (molds). The thermite turned into steel by contact melting from the ends of the rails are welded into the cavity (between the molds), performed diffusion material contribution to the basic material and thus lead to the achievement of intimate contact

without separation plan between the rails subjected to splice assembled. [1]

2. The experimental part

This paper presents the effects of micro-alloying steel with thermic modifier complex of $FeSi_{34}V_{25}Ti_{12}$ and FeB_{15} in a percentage of 1.5% and highlight the changes resulting from mechanical tests. The thermic steel analyzed, is obtained from French thermite. The railway rails welded are the type of 60E1 and the steel grade mark of R260.

The mechanical tests performed are hardness, static bending and bending shock. The strength tests tread rails welded and static bending tests were performed according SR EN 14730-1+A1:2011. In the Figure 1 and 2 are shown the location for strength stiffness testing and the bending test schematics.

¹ Polytechnic University of Bucharest

² The Romanian Railway Notified Body - NoBo

³ The National Railway Safety Agency - NSA / ASFR

3. Bending test shock (resilience)

The test specimens needed to achieve resilience test on welded samples were taken from the weld seam. The resilience values of welding samples are presented in Table 1 and have the following features which can be interpreted as:

The alloy that is resulting from melting thermite and the two ends of the track has a slightly modified structure of the French thermite unchanged, the direct effect of the means of: 5.38 J for the sample test without modifier and 8.32 J for the sample with complex modifier.

This growth increase can not be attributed only to realize synergistic effect modifier of the elements that make up the complex.

It is also remarkable often good uniformity values obtained on the five tests, which show a homogeneous hardware structure, as uniform.

4. Strength testings

The hard strength stiffness tests were carried out on a valuable tread of rails welded to the weld seam in three points. The obtained values from these tests are passed in Table 2.

According to the values in Table 2 is an increase in weld hardness average value 279 for steel thermic without modifying the average value of the hardness of the steel 292 with modifier.

At the same time it is observed that the weld strength obtained by micro-alloying with modifier complex of $FeSi_{34}V_{25}Ti_{12}$ and FeB_{15} in a proportion of 1.5%, does not exceed the hardness side rails, which are made of steel rails trademark R260, we can say that it has a hardness between 260 HBW and 300 HBW. Therefore we can say that by changing the hardness of steel thermic weld tends to reach the upper limit of the range of hardness of welded the

track rails.

5. The static bending tests

There have been two The static bending test aluminothermic welding in French thermic welding steel unchanged and French thermic welding steel as the modifier complex of $FeSi_{34}V_{25}Ti_{12}$ and FeB_{15} in a proportion of 1.5%. The static bending tests on these two aluminothermic welds were performed according to the method described in Annex F of SR EN 14730-1+A1:2011 and in Fig. no. 3.

The results from static bending tests are shown in Figure 3 for the sample without modifier and in Figure 4 for sample modified steel. The coupon resulting from rail tracks with French thermite weld was snapped broken unchanged from static bending test 707 kN and the coupon resulting from rail thermite welding track rails modified with modifier complex of $FeSi_{34}V_{25}Ti_{12}$ and FeB_{15} in a proportion of 1.5%, was broken in value 727 kN.

6. Conclusions

In conclusion, the thermic steel obtained by changing the chemical composition of thermite French with complex modifier ($FeSi_{34}V_{25}Ti_{12} + FeB_{15}$), in a percentage of 1,5%, higher values were obtained from testing the weld Strength, toughness testing, and the static bending test in comparison with the values obtained for the same test carried out with unmodified thermite steel made from thermic.

We assert that thermite can be optimized by microalloying since we have been obtained improvements in all mechanical tests performed.

Acknowledgements

The present paper is part of the researches included in the European Project The

Sectorial Operational Programme Human Resources Development
 POSDRU/6/1.5/S/16 “PhD

Candidates in Innovation and Competitiveness Support”, having regard the identification number of Contract - ID 5159.

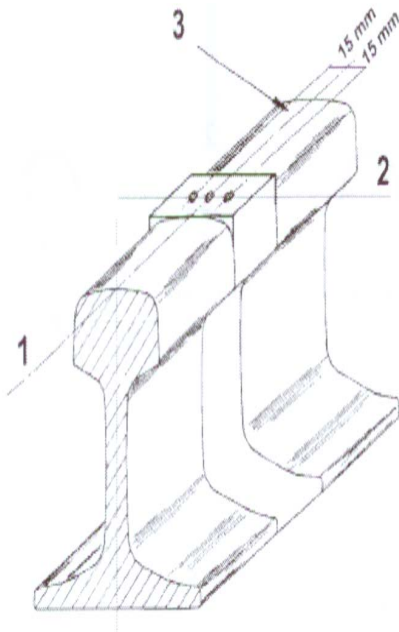

Fig. 1. The location for testing the strength slow

1 - the face longitudinal axis rolling;
 2 - the transversal axis of the weld; 3 - the running surface

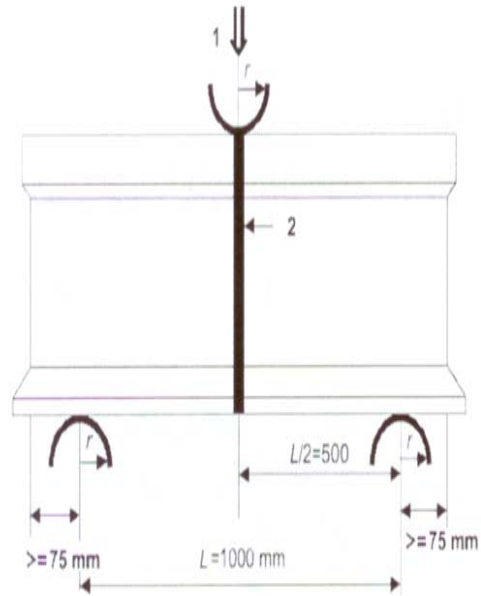

Fig. 2. The slow bending test scheme 1 - Load charging; 2 - Welding.

The sample test no. 1 (707 kN)

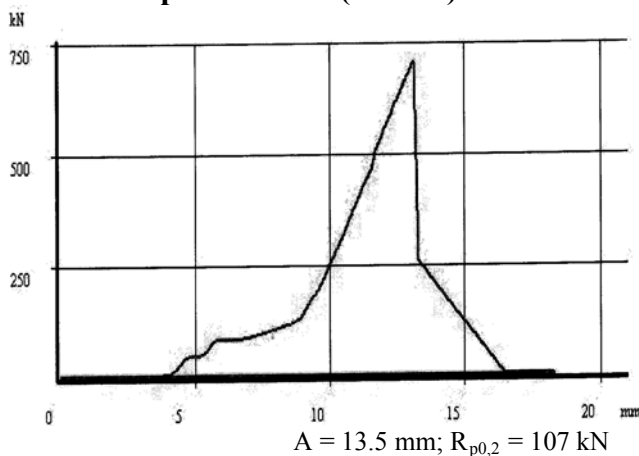

Fig. 3. The slow bending test results without modifying the sample

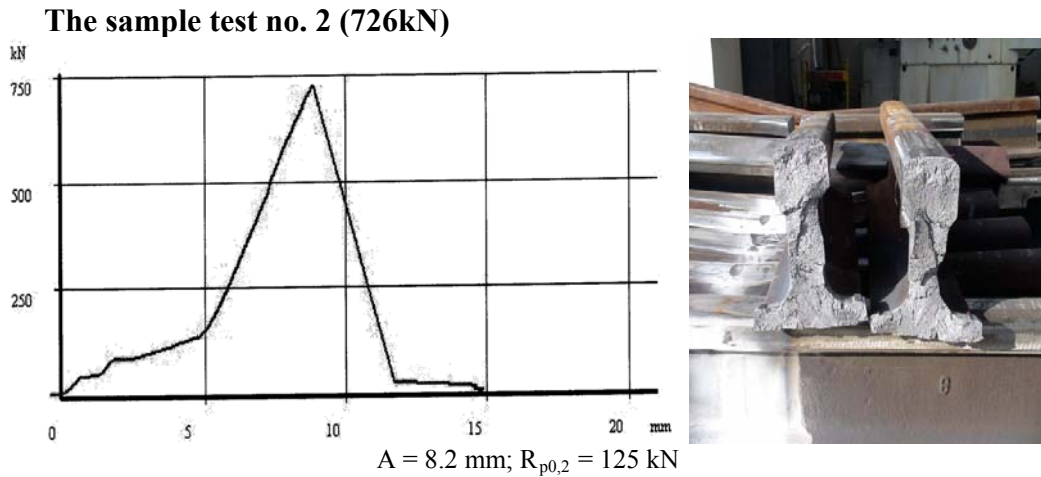

Fig. 4. The slow bending test results sample with modifier

Values obtained from test specimens taken from resilience weld Table 1

No.	The sample test	KCU [J]					middle value
		val.1	val.2	val.3	val.4	val.5	
1	Welding without modifying	4.8	4.6	6.4	5	6.1	5.38
2	Welding with modifying	8.2	8.6	8.3	8.3	8.2	8.32

The Brinell strength hardness values Table 2

No.	The sample test	Strength hardness [HBW]			
		val. 1	val. 2	val. 3	middle value
1	Welding without modifying	281	278	278	279
2	Welding with modifying	296	289	291	292

References

1. M. Adithan et al: *Manufacturing Technology*, New Delhi 2003
2. SR EN 14730-1+A1:2011: *Aplicații feroviare. Sudarea șinelor aluminotermic. Partea 1:*
3. <http://www.railtech.fr/>

Aprobarea procedeeor de sudare (Railway applications. Aluminotermic welding of track rails. First Part. The approval welding processes)