

# ADHERENCE STUDY BETWEEN ANCHORING MORTAR AND CONCRETE FOR POST-INSTALLED REBARS IN HARDENED CONCRETE

B. ROSCA<sup>1</sup>   Z. KISS<sup>2</sup>   V. COROBCEANU<sup>1</sup>

**Abstract:** *This paper presents a study of performance evaluation of adherence between anchoring cement-based mortar and concrete for post-installed steel reinforcing bars. A series of nonstandard tests were performed with the objective of assess the adherence at the boundary between anchoring mortar and support concrete. Pull-out test were performed to determine the adherence resistance mortar-to-concrete. The bond strength at this interface is assessed. The results are useful at the design phase of the post-installed rebar connections between and old concrete member and a new one.*

**Key words:** *adherence; cement mortar; anchoring; rebars; pull-out.*

## 1. Introduction

The adherence between the anchoring material and concrete is very important for the post-installed grouted anchors and the post-installed rebars. The grouted anchors are post-installed anchors with special mortars in a hole with diameter at least 1.5 times greater than nominal diameter of the anchor. The anchor can be a threaded rod or a headed rod.

A post installed rebar is a steel reinforcing bar installed with a special mortar in a hole with the diameter greater or equal to one than the nominal diameter of rebar. There are special resin mortars which allow a ratio  $r$  between diameter of the hole  $h_0$  and nominal diameter of the rebar  $d_s$  smaller than 1.5. Nowadays in a doctoral study at UTCN and UTI the

behaviour of the rebars, which are installed into the hardened concrete with cement-based mortars, having maximum aggregate size between 2 and 4 mm respectively is under way. Within this study the ratio  $r$  is greater than 1.5, for all rebars connection.

There is a difference between anchor theory and the rebars design. The anchor theory is based on theory developed by Eligehausen [1], Cook [2], Rehm [3] and supposes shallow embedment lengths, in general smaller than  $10d_s$  and the pull-out of the concrete cone is allowed.

Unlike the anchor theory, the rebars design is based on classical bond theory developed by most concrete structures standard [4], [5].

Regardless for a grouted anchor or a rebar connection the bond stress between concrete and the anchoring mortar is

---

<sup>1</sup> Faculty of Civil Engineering, Depart. of Concrete, Materials and Technology, Technical University of Iaşi.

<sup>2</sup> Faculty of Civil Engineering, Department of Structures, Technical University of Cluj Napoca.

important for the capacity of the created joint.

In both cases there is a failure mode which includes the failure by surpassing the bond strength between these two hardened materials. Therefore, in this study, the considered failure mode is by pulling-out of the mortar from concrete.

## 2. Objectives

The main objective was to determine the maximum bond stress at the boundary between concrete and the anchoring mortar using a head connector, so that the failure to occur at this interface. Besides, the hole cleaning effect on the bond stress at mortar-to-concrete interface was studied.

## 3. Materials and methods

The anchoring mortars are Portland cement-based mortars, which were developed into laboratory within the doctoral study foregoing mentioned. The constituents of the mortar are the Portland blended cement, sand, water and chemical admixtures. The cements used was blended Portland cements. In this study mineral admixtures, as the limestone and fly ash, added at the manufacturing of the blended cement are involved.

There were two blended cement used in this study namely, Portland-composite cement CEM II/A-LL 42,5 which include 6-20% limestone grounded with the Portland clinker at manufacturing and CEM II/AV 42,5 with 6-20% fly ash, respectively.

The aggregate consist of sand and was divided into two categories coarse and fine sand.

The natural river sand, which is considered round and less rough, was used. The maximum size of the coarse sand was 2 mm. A particular granular shape of the sand was developed in order to increase de

fluidity of the mixture and the packing density of the aggregate.

The used chemical admixture is the polycarboxylate superplasticizer (PCE).

The properties of the anchoring mortars are presented in Table 1 and Table 2.

Table 1

*Properties of limestone cement mortar*

<b>Compressive strength</b>	7 days	43 MPa
	28 days	52.5 MPa
<b>Tensile strength</b>	7 days	3.75 MPa
	28 days	4.05 MPa
<b>Elasticity modulus</b>	37000 MPa	
<b>Dry shrinkage; max. strain 56 days</b>	740 $\mu\text{m}$	

Table 2

*Properties of fly ash cement mortar*

<b>Compressive strength</b>	7 days	53.5 MPa
	28 days	63.5 MPa
<b>Tensile strength</b>	7 days	3.91 MPa
	28 days	4.25 MPa
<b>Elasticity modulus</b>	37000 MPa	
<b>Dry shrinkage; max. strain 56 days</b>	670 $\mu\text{m}$	

In Table 1 and 2 the average values of strength was rounded to 0.5MP and 0.1MPa for the compressive strength and tensile strength, respectively. The average value of elasticity modulus was rounded to 500 MPa.

A head connector, which consist of a rod threaded at the both end and a circular nut of  $\Phi 28\text{mm}$  diameter screwed at one end, was embedded into a hole of  $\Phi 30\text{mm}$  diameter, see Fig.2.

The embedment effective length was quite short equal to 45mm in order to avoid the yielding of the steel rod.

The length of the hole was 55mm because the depth of the nut is 10mm. The plate nut assured the verticality of the connector.

### 3.1. Installation of the connectors

The operations involved into the installation process are similar with the operations for bonded anchors. The involved operations into the process are:

- **Hole drilling.** There are many ways of drilling holes. For concrete, hammer drilling makes use of the hammer function of professional hammer drills and is best suited technology. Diamond core drilling is another method, but is less used for dry drilling, mostly for wet drilling. The hammer drill method was used.

- **Hole cleaning.** It is of critical importance to almost all adhesive anchor installations. If hole cleaning is not properly carried out in practice, then is frequently a major source of poor adhesive anchor performance. There are some cleaning procedures usually used to clean the drilled hole and the selection of it depends on the type of the bonding material used. Thus, for chemical adhesive anchors brushing with a stiff metal or nylon brush and blowing with sufficient compressed air is suitable, unlike the mortar grouted anchors where the brushing operations can be followed by water jet. In this study, for cleaning of the debris, a brushing operation followed by a water jet was used. After cleaning, in the case of mortar grouted anchors the hole must remain with water for 24 hours and the water must be evacuated a few hours before the installation. Thus, the mortar shall be placed in a damp hole.

- **Mortar preparing.** A mixer of 5l capacity having manual/automat capabilities was used to prepare the anchoring mortar, see Fig.1. The construction of the mixer fulfils the requirement of the standard SREN 196-1.

The superplasticizer was added after the 75% of water was previously mixed with the solid components.

At the time of installation, standard

mortar samples (prisms 40x40x160mm) were poured. The prove samples was tested at the same day with the test of the connectors, seven days age. The compression and indirect tensile tests were performed according to standard SREN 196-1.



Fig. 1. *Mortar mixer with manual/automat functions according to SREN 196-1 produced by ELE company*

- **Rebar installation.** First, the connector was inserted into the damp hole and second, the mortar was poured filling the empty space. The holes was drilled into 200mm concrete cubes of C20/25 class.



Fig. 2. *Installation of the head connector into the  $\Phi$ 30mm damp hole.*

**- Curing conditions.** The surrounded area of embedded connector were protected with a double thin sheet of plastic and the entire block of concrete was kept at the room temperature and humidity of  $(21\pm 2)^{\circ}\text{C}$  and  $(60\pm 10)\%$  RH, respectively.

A number of six installations were carried out. The installations are presented in Table 3.

Four type of mortars were involved. The mortar labelled ML is a limestone cement-based mortar and the mortar MV is a fly ash cement-based mortar. The composition of these two type of cement-based mortars are given in [6]. In this study each type of mortar was prepared with a water/cement ratio equal to 0.39 and 0.36 respectively. Two install conditions were considered, clean and damp hole and unclean hole.

*Installation characteristics Table 3*

Installation	Characteristic		Mortar		Install conditions
	Diam. (mm)	Embed length (mm)	Type	W/C	
1	30	45	ML1	0.39	Clean & Damp
2			ML2	0.36	
3				0.36	Unclean
4			MV1	0.38	Clean
5				0.36	& Damp
6			MV2		Unclean

**3.5. Assess method of the bond**

The selected method to assess the maximum bond stress at the boundary between anchoring mortar and concrete was pull-out method.

Because of this adherence study is done within a larger study about behaviour of post-installed rebars with cement-based mortars, the pull-out method was applied based on the information given in EOTA TR023 and SREN 1881. Both standards are limited to reinforcing steel bars designed in accordance with SREN 1992-1

The confined test is recommended by TR023 for pulling-out the rebars. In confined tests concrete cone failure is eliminated by the transferring the reaction force close to the anchor into the concrete, see Fig. 3.

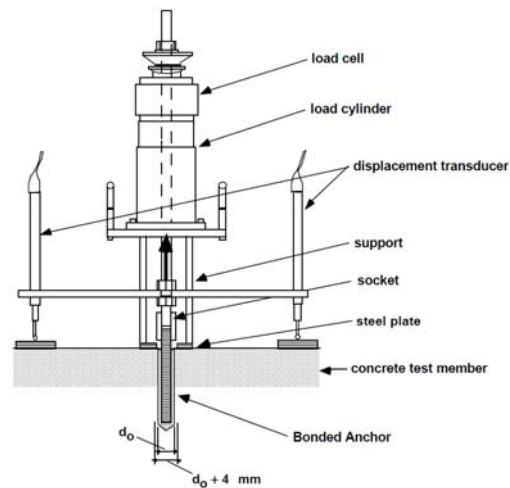

*Fig.3. Example of a tension test rig for confined tests according to [8]*

Based on the indication furnished by Fig.3, a tension test rig, which can be fixed on a universal testing machine, was developed. The tension test rig used at tests is given in Fig.4.

Considering the shallow embedment length in this study a confinement steel plate was added in order to avoid the influence on the failure mode of a small concrete cone, see Fig. 6.

Series of five specimens were involved into the test. The confined pull-out test were performed according to ETAG001 Part5 recommendations. The test was performed in load control and the pull out load was increased progressively in such away that the peak load occurred after 1 to 3 minutes from start time. Two mechanical displacement devices was used to assess the displacement of the loaded end of the connector. The recording frequency of the displacement was 0.25 Hz.



Fig.4. Developed tension test rig for confined tests

SREN 1504-6 and SREN 1881 impose that the displacement of the loaded end to a characteristic load, called the load control, shall be less than 0.6mm.

#### 4. Assessing of the post-installed head connector

The test was developed so that the induced failure mode consist of pulling-out of the mortar with the connector, and thus to calculate the developed bond stress at the boundary between concrete and mortar.

The embedment length of the mortar was set quite small to avoid the yielding of the steel rod and to calculate the maximum bond stress based on the uniform bond stress model, which is quite accurate for shallow embedment lengths.

##### 4.1. Calculation of the bond strength

The uniform bond stress is the most involved assessment model concerning the shear stress due to bond. The greater the embedment length the smaller the accuracy of the bond stress model.

According to CEB-FIP [4], [5], from the results of the tension tests the average bond strength is calculated according to

Equation (1)

$$f_{bm}^t = \frac{N_{um}}{\pi \cdot d \cdot l_v} \quad (1)$$

with

$f_{bm}^t$  = average bond strength in the test series

$N_{um}$  = average value of the failure  $N_{u(fc)}$  loads in the test series

$d$  = rebar diameter

$l_v$  = embedment length of the rebar in concrete

$N_{u(fc)}$  = failure (peak) load of an individual test

The peak load was considered as that indicated by TR023 because the results of this study are applied to the behaviour and the design of the post-installed rebars connections. Therefore, according to TR023 the failure peak load of the test is set conventionally as follows:

If peak load is reached at a displacement  $\delta \leq \delta_1$ , then use peak load as failure load.

If peak load is reached at a displacement load at  $\delta > \delta_1$ , then use load at  $\delta_1$  as failure load. The limit  $\delta_1$  is called maximum acceptable displacement and according to TR023 depends on the diameter of the rebar. In this adherence study, the considered  $\delta_1$  limit was equal to 1.5 mm.

Additionally according to SREN 1881 the displacement of connector to the load control  $F_c$ , was measured. Based on the bond stress level and the installation configuration emphasized by SREN 1881, the resulted control force for the installation configuration used in this study is equal to 20KN.

#### 5. Results and discussions

The unique recorded failure mode was at the boundary between concrete and mortar (C-M). In Fig. 5 the failure mode of the pull-out connectors is shown. In Fig. 6 the

influence of the confinement steel plate on the failure mode of the head connectors is shown. Without steel plate confinement a small concrete cone, which can influence the results, is developed. In Table 4 and Table 5 the experimental results of the pull-out tests of the connectors installed in a clean and damp hole with limestone cement-based mortar and fly ash cement-based mortar, respectively, are given.



Fig.5. The pull-out connector and the embedded mortar after the test

The bond resistance mechanism at the tension force consists in a strong adherence of the anchoring mortar to concrete and the friction between these two hardened materials. The friction starts where the adhesion is broken.



Fig.6. The pull-out connectors with (left) and no (right) steel plate confinement

Table 4  
Pull-out results at 7 days; limestone mortar

Characteristic		C20/25	
		h <sub>ef</sub> 45mm	
		Diam 30mm	
		Mortar	
		ML1	ML2
Average value of the failure loads N <sub>u(fc)</sub>	N <sub>um</sub>	3.46	3.80
Average bond strength of the test	f <sub>bm</sub>	8.05	8.95
Displacement at the control load	δ <sub>c</sub> mm	min.	0.51
		max	0.64
Max. displacement at the failure loads N <sub>u(fc)</sub>	δ <sub>max</sub> mm	min.	1.50
		max	1.5
Average maximum failure force	F <sub>max,failure</sub> (tf)	3.65	3.92
Failure mode through:		C-M	C-M

Table 5  
Pull-out results at 7 days; fly ash mortar

Characteristic		C20/25	
		h <sub>ef</sub> 45mm	
		Diam 30mm	
		Mortar	
		MV1	MV2
Average value of the failure loads N <sub>u(fc)</sub>	N <sub>um</sub>	3.91	4.10
Average bond strength of the test	f <sub>bm</sub>	9.21	9.64
Displacement at the control load	δ <sub>c</sub> mm	min.	0.31
		max	0.49
Max. displacement at the failure loads N <sub>u(fc)</sub>	δ <sub>max</sub> mm	min.	1.26
		max	1.50
Average maximum failure force	F <sub>max,failure</sub> (tf)	4.27	4.42
Failure mode through:		C-M	C-M

The displacement of the connector at the control load is smaller than 0.6mm for all clean and damp hole cases. The maximum recorded displacement is even less than 0.5 mm for mortar ML2 and MV2.

The maximum bond stress (bond strength) is greater for fly ash cement-based mortar than limestone cement-based mortar. The difference is approximate 1-2 MPa.

In both cases the maximum bond stress

is greater for mortar mixture prepared with a smaller water/cement ratio. However, the difference is less than 1 MPa.

In Fig.7 and Fig. 8 examples of bond-slip behaviour of the post-installed head connector with limestone mortar to tension are plotted. Thus according to TR023, see 4.1, in Fig. 7 is plotted a bond-slip behaviour where the failure load is equal to maximum failure force and in Fig. 8 the failure load is equal to the corresponding force of a maximum admissible displacement  $l$  equal to 1.5mm.

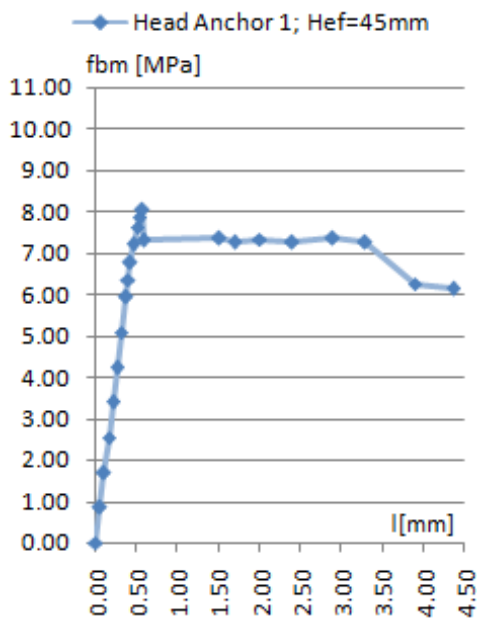

Fig.7. Bond-slip behaviour; mortar ML1

In Table 6 the experimental results of the pull-out tests of the connectors installed in the uncleaned hole with limestone cement-based mortar and fly ash cement-based mortar, respectively, are given.

In the unclean hole case the bond strength is strongly reduced more than 50% and the failure load is smaller than control load.

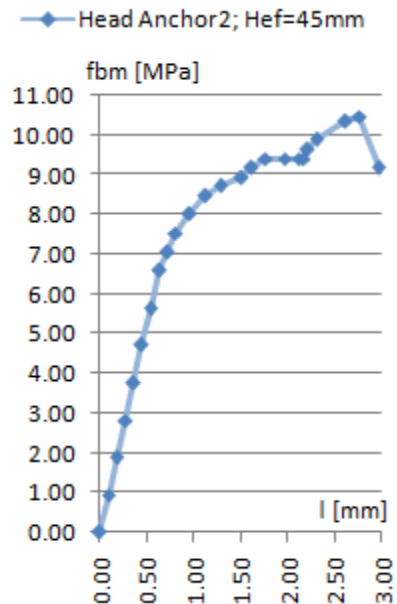

Fig.8. Bond-slip behaviour; mortar ML2

Table 6  
Pull-out results; uncleaned hole

Characteristic	C20/25		
	$h_{ef}$ 45mm		
	Diam 30mm		
Mortar			
ML2			
MV2			
Average value of the failure loads $N_{u(fc)}$	$N_{um}$	1.46	1.98
Average bond strength of the test	$f_{bm}$	3.44	4.66
Displacement at the control load	$\delta_c$ mm	min.	-
		max.	-
Max. displacement at the failure loads $N_{u(fc)}$	$\delta_{max}$ mm	min.	1.5
		max.	1.5
Average maximum failure force	$F_{max, failure} (tf)$	1.46	1.98
Failure mode through:		C-M	C-M

## 6. Conclusions

Within the behaviour of the post-installed rebars to tension force, the adherence between anchoring hardened mortar and the concrete is important, because in some circumstances the failure mode of the rebar connections could take

place at the interface between the two materials.

The adherence study was carried out with two types of mortar developed into laboratory. By designing of the mixture, special flowing and stability characteristics were established. Also, the mortars provide high strength and elasticity modulus.

The study is limited to one installation configuration concerning to the embedment length, the hole diameter and the concrete strength class. More studies with greater embedment lengths and with concrete of higher class should be performed.

The bond stress values provided by adherence of the two materials assure a good level of safety against the failure at the concrete-mortar interface for rebars to tension load where the ratio between hole and the rebar diameter is greater than 1.85. For smaller ratio  $r$  doesn't have information, but based on the equation (1) the bond stress level at this interface increases very close the bond strength presented in Table 4 and 5.

It is strongly recommended to clean the hole before installation of the rebar. If the rebar is installed in a uncleaned hole, the capacity of the rebar connection is strongly reduced and the failure mode shifts from the rebar-mortar to the concrete-mortar interface.

## References

1. Eligehausen, G.: *Anchorage in Concrete Construction*. Ernst & Sohn GmbH & Co.KG, 2006.
2. Cook, R., Fagundo F.E., Biller M.H., și Richardson D.E.: *Tensile behavior and design of single adhesive anchors*. Report FL/DOT/RMC/0599-3668, Civil Engineering Department, University of Florida, SUA, Gainesville, 1991.
3. Eligehausen, R., Mallee R, and Rehm G.: *Fixing formed with resin anchors*. Betonwerk + Fertigteil-Technik, No. 10, No. 11, No,12, 1984.
4. CEB-FIP: *Model code 2010, First complete draft, Volume No.1*, Bulletin No. 55. March, 2010
5. CEB-FIP: *Bond of Reinforcement in Concrete, State of the Art Report*, Bulletin, No. 10 August, 2000.
6. Rosca, B., *Experimental study on the behaviour of post-installed rebars with cement-based mortar in hardened concrete*. Research Report No. 01, Concrete, Materials and Technology Departement, Technical University of Iasi, 2014
7. \*\*\* TR023: *Assessment of post-installed rebar connections*. European Organization for Technical Approvals EOTA, 2006.
8. \*\*\* EN 1881: *Produse și sisteme pentru protecția și repararea structurilor de beton. Metode de încercare. Încercarea produselor pentru ancorare prin metoda smulgerii*, ASRO, 2007.
9. \*\*\* SR EN 1992-1: *Eurocod 2: Proiectarea structurilor de beton. Partea1-1: Reguli generale și reguli pentru clădiri*, ASRO, 2006.
10. \*\*\* ETAG001-Part5: *Guideline for European technical aproval of metal anchors for use in concrete. Part 5 Bonded anchors*. EOTA, 2002
11. \*\*\*SR-EN1504-6. *Produse și sisteme pentru protecția și repararea structurilor de beton - Definiții, condiții, controlul calității și evaluarea conformității. Partea 6 - Ancorarea barelor de oțel pentru armare*. ASRO, 2008.
12. \*\*\*CEN/TS 1992-4-1: *Design of fastenings for use in concrete. Part 4-1: General*. CEN, 2009.