

FAILURE MODES AND DESIGNING PROCEDURES OF THE TUBULAR TRUSS BEAMS WELDED JOINTS ACCORDING WITH EN 1993-1-8

D. RADU¹ A. SEDMAK²

Abstract: *The paper presents the particularities of the truss elements welded joints failure modes and design for RHS or CHS diagonals and IPE or HEA chords. The design of these joints is regulated by Eurocode EN 1993-1-8 standard. Regarding the designing and manufacturing of the steel structures, the implementation of the European standards in Romania led to a design with complex checking possibilities, taking into account different failure modes. Also the implementation of EN 1090-2 standard for quality control, produced a better manufacturing control of the steel structure joints. The most economical solution to join tubular cross section truss elements is with direct welding – no additional steel plate. The joining type can vary from T or Y to K or N type with overlapping or with gap between the welded elements.*

Key words: *Steel truss beams joints, welded joints, steel structures*

1. Introduction

From the global analysis point of view, as for any truss beam type, it is considered that the truss elements are pinned end connected to the continuous upper and lower chords. The distribution of the axial forces is done taking into account this assumption.

The main problem that appear in the truss beams joints is the axially of the forces. In case of eccentricities, these are producing additional bending moments in nodes and elements. The main concern in the designing of a joint is to identify the importance of these residual efforts which can lead to different types of joint failure.

The truss element joining technology plays a major role in the tubular cross sections structures performances. The most common and economic solution for rectangular hollow section profiles is directly through weld without any gusset or additional steel plate. This solution is the most efficient regarding the maintenance and anticorrosive protection. The joints can be easily manufactured, considering that the joining elements must be only cut in shape and welded together.

Following this procedure, can be made various types of joints – from T and Y for the in plane truss beams to double K and duple X for the reticular truss structures.

¹ Faculty of Civil Engineering, Transilvania University of Brasov

² Faculty of Mechanical Engineering, University of Belgrade

2. Design of the joints and failure modes

In design practice there are commonly met several types of tubular truss beams elements welded joints (Figure 1). Each type presents several failure modes which are the basis of the Eurocode checking procedures.

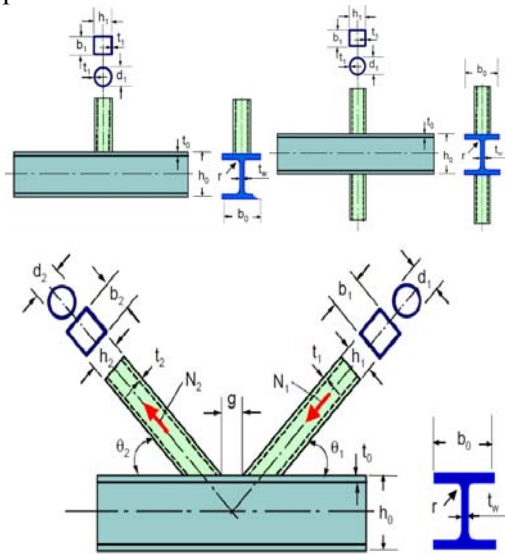

Fig. 1. *Welded joints types for CHS or RHS truss elements with the I or H type truss chord*

In case of eccentricities which introduce secondary bending moments, these can be neglected for the design of the joints and for the truss elements if the geometrical conditions are satisfied [1]. Also the truss diagonals can be considered as pinned in the upper and lower chords and the chords can be considered as continuous beams pinned in the end joints.

In a truss beam with RHS/CHS diagonals and I or H type chords, failure modes under axial force of the joints (figure 2) can be classified as following:

- (a) Failure of the web of the chord under compression effect of the diagonal
- (b) Failure due to share of the chord

- (c) Failure of the diagonal on an effective area (cracks in the welding or diagonal)
- (d) Failure of the truss element (diagonal) through local yielding and buckling.

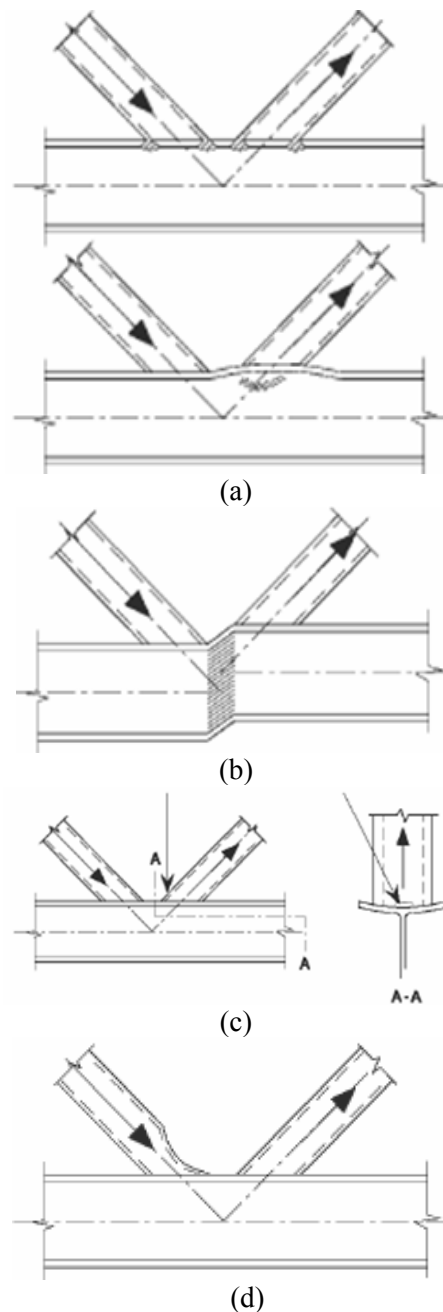

Fig. 2. *Failure modes of the joints for truss beams with RHS/CHS diagonals and I or H chord profile type.*

2.1. Failure of the web of the chord under compression effect of the diagonal

The diagonal axial force is transmitted through an effective area toward the chords web in the position where the walls of the diagonals are connected to the flange of the chord (figure 3).

The failure mode is assessed through a dissemination of the stresses shown in figure 3, resulting the assimilation with beam to column joint.

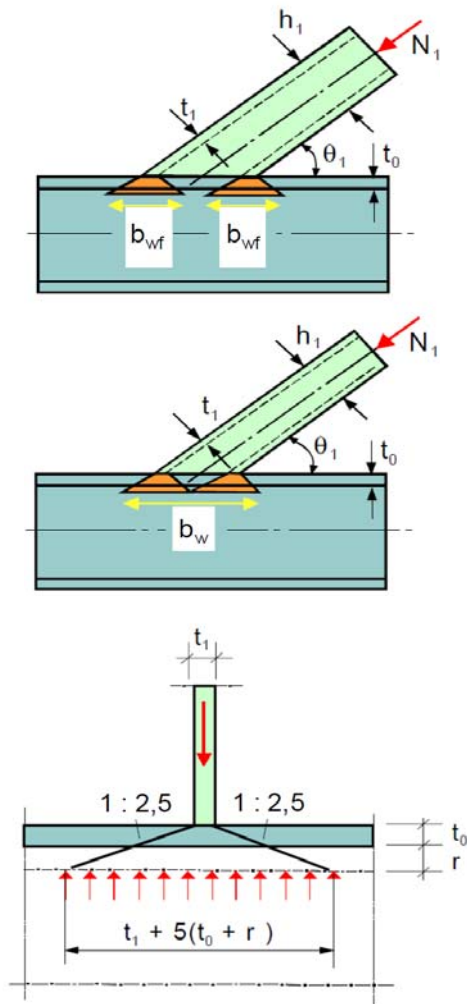

Fig. 3. Model of the chord web failure under compression effect of the diagonal

Thus the checking is:

$$N_i \cdot \sin \theta_i = f_{y0} \cdot t_w \cdot b_w / \gamma_{M5}, \quad (1)$$

$$\text{where } b_w = \frac{h_i}{\sin \theta_i} + 5 \cdot (t_0 + r) \quad (2)$$

2.2. Failure due to share of the chord

The EN 1993-1-8 presents an interaction formula for the share and axial force combined effect. The share effect appear in the space between the diagonals joints. In case of small gaps between the diagonals joints, when the chords web is yielding, also the chords flange takes the share effect. Considering these effects, the European normative [1], conditions the gap dimension to $g \geq t_1 + t_2$, where t_1 and t_2 represents the diagonals walls thickness. Also the eccentricity must be lower than $0,25 \cdot h_0$, where h_0 represents the height of the truss beam chord profile.

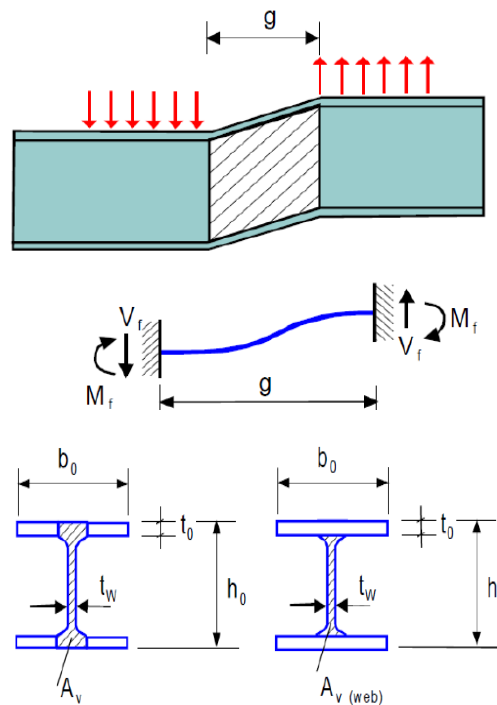

Fig. 4. Model of the chord in share failure

The bending moment in the flange is:

$$M_f = \frac{V_f \cdot g}{2} \quad (3)$$

The interaction formula for the chord is:

$$\left(\frac{M_f}{M_{pl,f}}\right)^2 + \left(\frac{V_f}{V_{pl,f}}\right)^2 = 1,0 \quad (4)$$

where:

$$M_{pl,f} = \frac{b_0 \cdot t_0^2}{4} \cdot f_{y0} \quad (5)$$

$$\text{and } V_{pl,f} = b_0 \cdot t_0 \cdot \frac{f_{y0}}{\sqrt{3}} \quad (6)$$

Replacing the terms in the above equation, it results:

$$\frac{M_f}{M_{pl,f}} = \frac{V_f}{V_{pl,f}} \cdot \frac{2 \cdot g}{t_0 \cdot \sqrt{3}} \quad (7)$$

The solution of the equation is:

$$\frac{V_f}{V_{pl,f}} = \sqrt{\frac{1}{1 + \frac{4 \cdot g^2}{3 \cdot t_0^2}}} \quad (8)$$

Thus, for a I or H chords profile, the active area which is take into consideration is:

$$\alpha \cdot b_0 \cdot t_0$$

where:

$$\alpha = \sqrt{\frac{1}{1 + \frac{4 \cdot g^2}{3 \cdot t_0^2}}} \quad (9)$$

For high profiles, the effective area of the chords profile is narrowed to area of the web without taken into account the flanges of the chord.

The checking of the share failure is:

$$N_{i,Rd} = \frac{f_{y0} \cdot A_v}{\sqrt{3} \cdot \sin \theta_i} / \gamma_{M5} \quad (10)$$

2.3. Failure of the joint weld

In order to avoid the weld failure, is recommended that the welds to be designed at a resistance force higher than the effective

element force – the capable force of the element itself.

For structural joints it is used the arc welding with filling material. There are some exceptions where the contact welding is used (e.g. Nelson bolts).

The most common welding types are corner or V with preprocessing of the elements edges.

In case of corner welding, the internal stresses are decomposed in parallel and normal stresses type in critical section of the welding strip (figure 5).

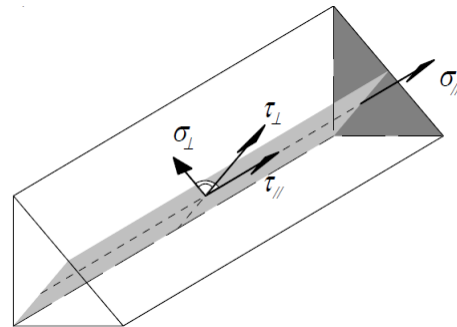

Fig. 5. Stresses of the corner welding

Considering an uniform distribution of the stresses in the critical section of the welding strip, the following tangential and normal stresses appear:

- σ_{\perp} - Normal stress perpendicular to the critical section of the welding strip
- $\sigma_{//}$ - Normal stress parallel to the welding strip axis
- τ_{\perp} - Tangential stress in the critical cross

section of the welding strip – perpendicular to the welding strip axis.

- $\tau_{//}$ - Tangential stress in the critical cross

section of the welding strip – parallel to the welding strip axis.

The design of the welding can be done with two methods:

- directional method
- simplified method

According with directional method, the strength of the welding will be sufficient if there are fulfilled two conditions:

$$\sqrt{\sigma_{\perp}^2 + 3 \cdot (\tau_{\perp}^2 + \tau_{\parallel}^2)} \leq \frac{f_u}{\beta_w \cdot \gamma_{M2}} \quad (11)$$

$$\text{and } \sigma_{\perp} \leq \frac{0,9 \cdot f_u}{\gamma_{M2}} \quad (12)$$

where β_w represents a correlation coefficient according to steel type (Table 4.1. – [1]), and f_u is the nominal value of the tension resistance of the weakest part of the joint.

The Eurocode [1] presents also a simplified procedure in order to assess the welding resistance without considering the load direction (figure 6). Thus, irrespective of the welding designed area orientation toward the applied force, the resistance force $F_{w,Rd}$, can be determined with relation:

$$F_{w,Rd} = f_{vw,d} \cdot a \quad (13)$$

Where

$$f_{vw,d} = \frac{f_u}{\sqrt{3} \cdot \beta_w \cdot \gamma_{M2}} \quad (14)$$

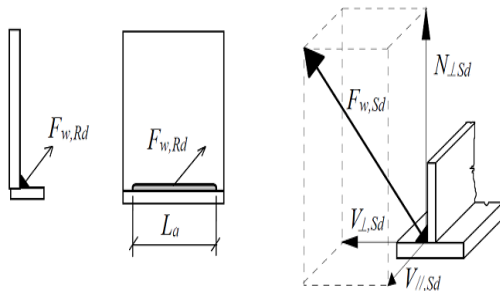

Fig. 6. Simplified method for corner welding design

2.4. Failure of the truss element (diagonal) through local yielding and buckling

It can be applied the same procedure as for the beam to column joint. Thus:

$$N_i = 2 \cdot f_{yi} \cdot t_i \cdot b_{eff} / \gamma_{M5} \quad (15)$$

where:

$$b_{eff} = t_w + 2 \cdot r + 7 \cdot \frac{f_{y0}}{f_{yi}} \cdot t_0 \quad (16)$$

In case of $b_{eff} > b_i$, conservatively is taken also the perimeter of the joint (figure 7).

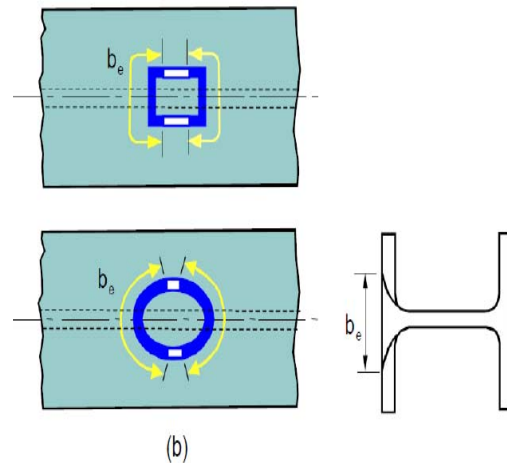
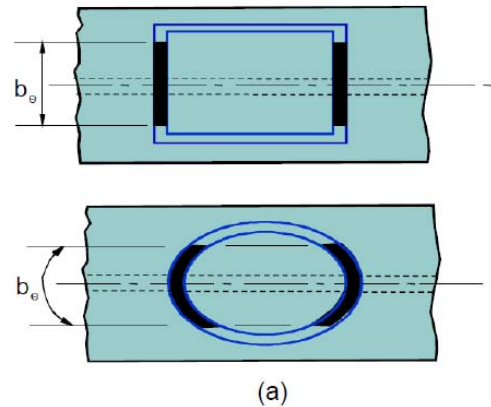

Fig. 7. Model for Failure of the truss element (diagonal) through local yielding and buckling

3. Conclusions

The increasing of the use of tubular cross section elements for structural purposes, lead to the development and implementation of general design rules for truss beams joints.

The Eurocode 1993-1-8 implementation in the designing of the welded joints, have the advantage of a correct dimensioning / check for these type of connections and the possibility of large scale use of the in contact welded solution (without any gusset).

References

1. SR-EN 1993-1-8:2006 *Proiectarea structurilor de oţel. Partea 1-8: Proiectarea îmbinărilor*, Editura ASRO
2. EN1090-2:2008 – *Execution of steel structures and aluminum structures – Part2: Technical requirements for steel structures.*
3. *Calculul și proiectarea îmbinărilor structurale din oţel în conformitate cu SR-EN 1993-1-8. Recomandări, comentarii și exemple de aplicare – Redactarea II*, Timișoara 2010
4. L. Wardenier, J.A.Packer, X.-L.Zhao and G.J.van der Vegte: „*Hollow Sections in Structural Applications*”, CIDECT, Geneva 2010