

STUDY OF EFFECTS OF VIBRATIONS CAUSED BY RAILWAY TRAFFIC TO BUILDINGS

R. NERIŞANU¹ D. DRĂGAN¹ M. SUCIU¹

Abstract: *The paper presents the manner in which railway traffic affects the buildings in the vicinity of the railways. Railway vehicles in motion produce high intensity vibrations. The way such vibrations affect the buildings depends upon the distance at which constructions are placed, the traffic speed of the rolling material, the axle load, the state of the railway, the kind of soil and last but not least the type of the foundation. The paper is divided into two parts, a theoretical part dealing with building dynamics, magnitudes quantifying vibrations, characteristics of vibratory motion, and a practical part where the results of the measurements are presented (regarding acceleration, speed, displacement, frequency) to highlight the detrimental effects of vibrations produced by the rolling stock in motion upon the buildings in the neighbourhood of the railways. Relevant photos are also given.*

Key words: *vibrations, rolling stock, in depth waves, surface waves, buildings.*

1. Introduction

The activity in contemporary society cannot be imagined today without transportation which expanded in time together with the increase of demands to displace both people and goods.

Transports have an important weight in the economy of states and are seen as integrant part of the environment. However, their impact upon the environment and upon the buildings in the neighborhood of communication ways is diverse and intense. The paper highlights the negative effects that transport systems, especially railways, produce upon constructions. There will be shown: the calculation of the vibrations produced by the rolling stock in

motion, the propagation of the vibrations in the soil, the results of the measurements performed with the purpose of highlighting the detrimental effects as well as relevant pictures.

2. Theoretical notions

2.1. Characteristics of vibrations

The vibratory motion or the vibration represents a type of behaviour of the rolling stock, appearing because of repetitive relative motions around the position of equilibrium and according to specific variation laws.

Vibrations are elastic waves transmitted through solid environments, which brings

¹ Faculty of Civil Engineering, Technical University of Cluj-Napoca.

in their name as *solidian waves*.

Experimentally, vibrations can be measured with respect to displacements, speeds and accelerations. The parameters defining vibrations are:

- displacement (X), expressed in m, cm and mm;
- velocity (v), expressed in m/s, cm/s and mm/s;

$$X_{\text{ef}} = X_{\text{rms}} = X = \frac{\sqrt{2}}{2} X_{\text{max}} = 0,707 X_{\text{max}} \quad (1)$$

Mention should be made that the measuring instruments of vibration measurement devices are gauged in effective values.

The kinematic parameters (X , v , a) are expressed through specific absolute values or through values called levels, defined by relationships of the form below:

$$L = 20 \lg \frac{m}{m_0} \quad (2)$$

where:

m – is the measured value of the kinematic parameter in question;

m_0 – is the reference value for the same parameter..

In order to characterize the effects of vibrations as influenced by frequency, one makes use of the concept of *vibration intensity level*. This is expressed through the magnitude called *intensity of vibration*, which can be defined by the relationship:

$$A = \frac{a_{\text{max}}^2}{f} = 16\pi^2 v^2 X_{\text{max}}^2 \quad (3)$$

where A is expressed in cm^2/s^3 , a_{max} represents the maximum acceleration in $[\text{cm}/\text{s}^2]$, and f , frequency is expressed in [Hz];

or,

$$S = 10 \lg \frac{A}{A_0} \quad [\text{number of vibrations}] \quad (4)$$

- acceleration (a), expressed in $\text{m}/\text{s}^2, \text{cm}/\text{s}^2$ and mm/s^2 ;
- frequency (f), expressed in Hz.

In order to define the amplitude of these vibrations, peak values can be used, such as, X_{max} , v_{max} , a_{max} or effective values. Between the maximum and effective values, there occurs the relationship:

where, $A_0 = 10^{-1} \text{ cm}^2/\text{s}^3$ represents the reference value.

Vibration intensity level can also be calculated with respect to any kinematic parameters measured at frequency f , with the relationships:

$$S = 20 \lg \frac{X}{X_0} + 30 \lg f \quad (5)$$

$$S = 20 \lg \frac{v}{v_0} + 10 \lg f \quad (6)$$

$$S = 20 \lg \frac{a}{a_0} + 10 \lg f \quad (7)$$

where: $X_0 = 0,008 \text{ cm}$; $v_0 = 0,05 \text{ cm/s}$; $a_0 = 0,316 \text{ cm}/\text{s}^2$.

For the protection to vibrations effects, one uses the concept of *equivalent vibration intensity level*, S_{ech} , which also considers the duration of the vibrations, through the number of cycles. The formula for S_{ech} is the following:

$$S_{\text{ech}} = 10 \lg \frac{1}{N} \sum_{i=1}^m n_i 10^{\frac{S_i}{10}} \quad (8)$$

2.2. The vibrations of vehicles on rails

In order to keep the railway transportation as a very important one, it is necessary to reach higher and higher traffic speeds and to consistently improve the

comfort of the passengers.

As compared to the dislevelments of the roads, those of railways are very small. However, because of the unsuspended large weights and because wheels and rails are made from steel even these small dislevelments can lead to relatively large shocks.

Other sources of shock and vibrations can be:

- the variation of the displacement speed;
- rail joints play;
- dislevelments;
- curves;
- excentricities and shape deviations of the running surfaces of tires;
- the pulls during manoeuvres, breaks and accelerations.

Horizontal and vertical vibrations in the suspension vehicle gear box are given by the periodic horizontal and vertical movements of the axles. As they are periodical and permanent during running, the vibrations form, in fact, the basic vibrations of the vehicle box having a decisive importance for the running quality. The vibrations present frequency ranges between 8 and 20 Hz, much higher than basic frequencies.

The own frequencies of the vibratory systems of the vehicles depend upon their constructive features, size, weight and inertia moments.

They are not affected by the travelling speed. At a certain speed, the frequency of forced vibrations can be equal to own vibrations frequency, leading to the resonance phenomenon. In such a case, for the degree of freedom in question, very high amplitude and acceleration values are met. One cannot act upon the frequencies of disturbing vibrations produced by the rolling track. It is for this reason that are searched solutions to intervene upon the vehicle own vibrations frequencies.

2.2.1. Own vibrations of rail vehicles

In order to study the own vibrations of a vehicles on the railway, we will take the diagram from Figure 1, where the vehicle is considered to travel along a completely stiff runway and the gravity centre of the unsuspended part does not coincide with the axis of symmetry of the car box, that is $l_1 \neq l_2$ and $a_1 \neq a_2$.

The system under discussion has three degrees of freedom, with generalised coordinates z , φ and θ , where z represents the vertical displacement of the car box, φ is the rotation angle (galloping, pitching) of the box around the cross section axis $O_1 - O_1$ and θ is the rotation angle (rolling) around the longitudinal axis $O_3 - O_3$.

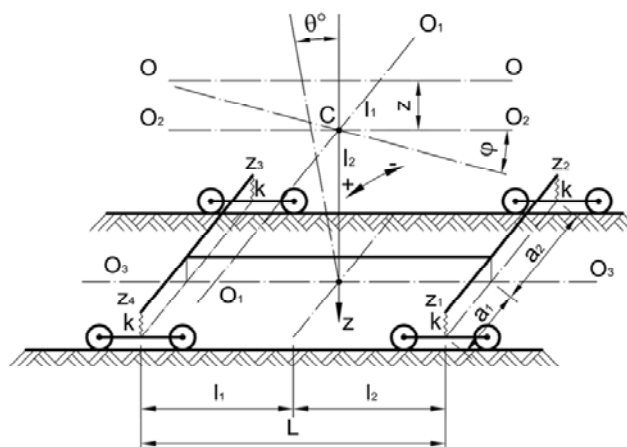

Fig. 1. Diagram for the calculus of the own vibrations of a railway vehicle

In Figure 1, we also noted: z_1, z_2, z_3 și z_4 – the displacements of the elastic elements of the suspension, k – the elastic constant of a spring; I_1 și I_2 – the moments of inertia of the vehicle box with respect to axes $O_1 - O_1$, respectively $O_2 - O_2$; M – vehicle weight.

The differential equations defining own vibrations are of the form:

$$\begin{cases} M\ddot{z} = -k(z_1 + z_2 + z_3 + z_4) \\ I_1\ddot{\phi} = -(z_1 + z_2)kl_2 + (z_3 + z_4)kl_1 \\ I_2\ddot{\theta} = (z_2 + z_3)ka_2 - (z_1 + z_4)ka_1 \end{cases} \quad (9)$$

The full calculus of the own vibrations of the rolling stock in motion is presented in

paper [1]. All the results of this calculus depend upon displacements.

2.2.2. Forced vibrations of rail vehicles

We go on with the presentation of forced vibrations in the case of a vehicle moving along a railway with dislevelments and whose values for the rolling wheels are z_{k1}, z_{k2}, z_{k3} , respectively z_{k4} (Figure 2).

The differential equations defining the forced vibrations of the system take the form:

$$\begin{cases} \ddot{z} + b_1z + b_2\phi + b_3\theta = A_1 - B_1 \cos(\omega t - \delta_1) \\ \ddot{\phi} + b_4\phi + b_5z + b_6\theta = A_2 - B_2 \cos(\omega t - \delta_2) \\ \ddot{\theta} + b_7\theta + b_8\phi + b_9z = A_3 - B_3 \cos(\omega t - \delta_1) \end{cases} \quad (10)$$

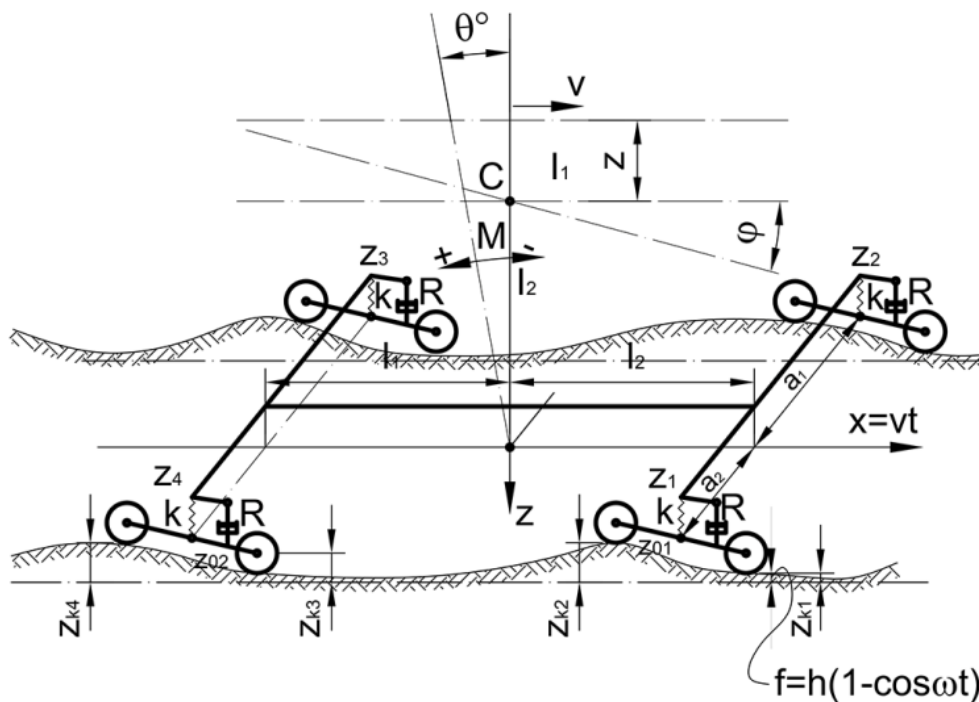

Fig. 2. Calculus of forced vibrations of a railway vehicle

The values of the coefficients $A_1, A_2, A_3, B_1, B_2, B_3, b_1, b_2, \dots, b_9$, and the full calculus of forced vibrations of the rolling stock are given in detail in reference [1].

2.2.3. Propagation of vibrations in the foundation ground

Vibrations are produced by large forces exerted between rails and wheels.

These forces fluctuate as a consequence of wheel and rail roughness, in a wide range of frequencies.

Moreover, the distribution of the axis load, in the trains, produces an additional excitation force because the axis passes through a fixed point.

This effect leads to excitations that have frequencies corresponding to vehicle in traffic frequencies.

Their effect is harmonic, when the forces corresponding to wheel and rail roughness possess a period determined by the vibration wavelength caused by roughness and the vehicle rolling speed.

The mixed vehicle-rail system is quite complex and has many own frequencies. When one of the frequencies of the disturbing forces corresponds to one of the own system frequency, a very strong vibration occurs.

Strong vibrations appear also when one of the frequencies of the disturbing force or a natural frequency of the system corresponds to the frequency which appears when vehicles pass over the cross ties.

Own frequencies are not dependent upon the rolling speed, while the frequency occurring when crossing the cross ties increases proportionally to the rolling speed.

When the rolling speed increases, a coincidence of frequencies takes place, the vibration reaches the maximum value and then it diminishes.

Hence, vibrations do not constantly grow with speed and the reduction of the speed can sometimes worsen the vibrations.

Vibrations propagate from the railway to the ground as compression waves, transverse waves and surface waves (Rayleigh waves).

For every kind of wave, the energy diminishes with the increase of the distance to the source.

This happens because of the geometrical damping and of the capacity to absorb energy of the ground.

At least, low frequencies are damped. The mechanism of the propagation of main surface railway induced vibrations as Rayleigh waves is drawn in Figure 3.

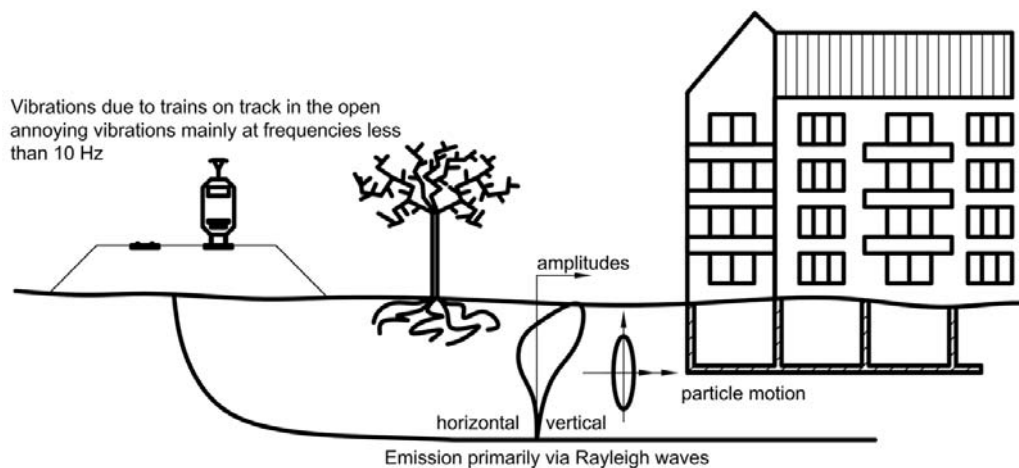

Fig. 3. *Propagation of vibrations in surface railways*

3. Case study

In order to show the effect of vibrations upon constructions, measurements of kinematic magnitudes were performed, in dwelling buildings placed in the vicinity of the railways.

Measurements were performed with the help of the PULSE Type 3560-C – Portable Data Acquisition Unit, up to 17 Input Channels and of the accelerometers Miniature DeltaTron Types 4507 and 4508.

The results of the measurements have been processed with the software *PULSE Labshop*. Measurements concerned constructions situated at a distance between 10 and 30 meters from the railway.

The measuring device mentioned earlier measures the accelerations of the vibrations. The values found and the software *PULSE Labshop* were then used to find the values for speeds, displacements and frequencies. The effects of the vibrations upon dwelling buildings in the neighbourhood of the railway are also presented in relevant pictures shot on the ground.

3.1. Results

For the kinematic values measured, we calculated vibration intensity level, when $N = 1$ and $N = 10^6$ cycles.

- Apahida commune – slow train – 5 cars; distance to the source = 18m (figurile 4, a, b, c, d).

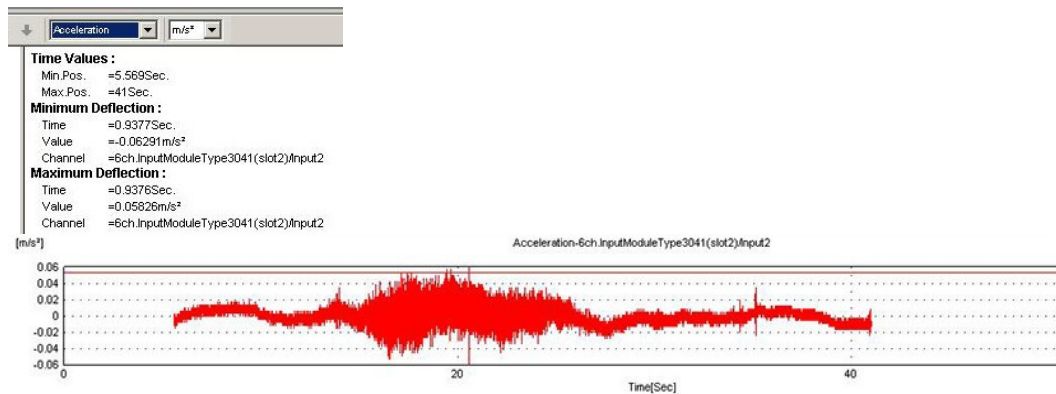

Fig. 4, a. Accelerations diagram

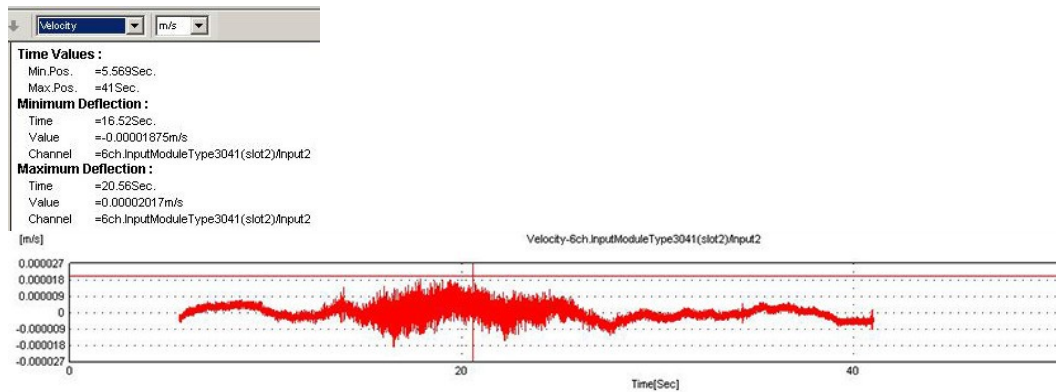

Fig. 4, b. Velocities diagram

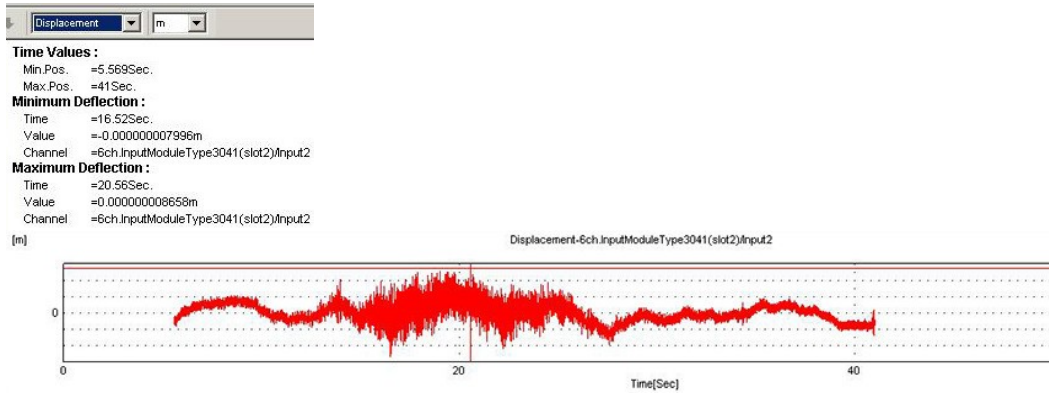

Fig. 4, c. *Displacements diagram*

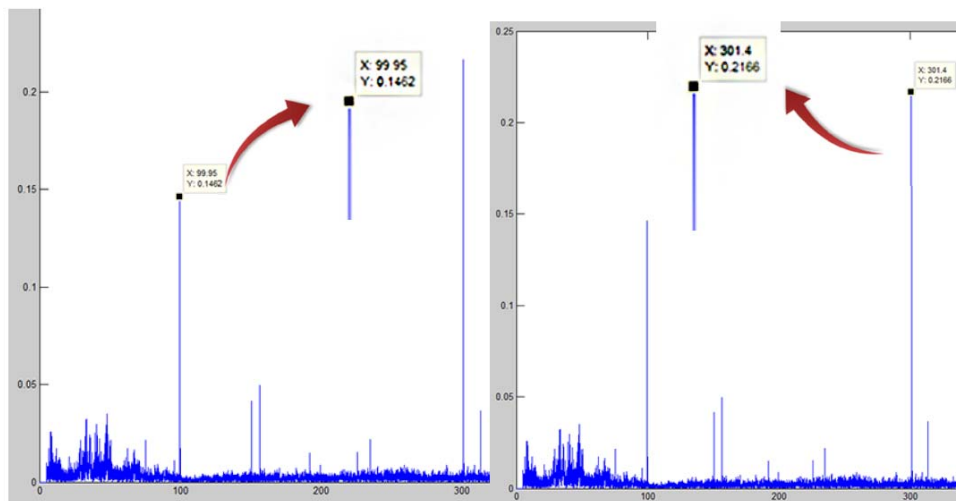

Fig. 4, d. *Values for amplitudes and frequencies*

Calculus of the vibration intensity level, S [no. of vibrations] – for N=1 Table 1

	a	a²	f	A	A₀	A/A₀	lg A/A₀	S
v1	0,1462	0,02137	99,95	0,00021	0,10	0,00214	-2,6699	-26,699
v2	0,2166	0,04692	301,4	0,00016	0,10	0,00156	-2,8078	-28,078

Calculus of the vibration intensity level, S [no. of vibrations] – for N=10⁶ Table 2

	S_i – a	S_i/10	$\frac{S_i}{10^{10}}$	N	1/N	n_i	lg[...]	S
v1	0,1462	0,01462	1,034236832	10 ⁶	1E-06	10 ⁶	6,01462	60,1462
v2	0,2166	0,02166	1,051138637	10 ⁶	1E-06	10 ⁶	6,02166	60,2166

3.2. Relevant pictures

See Figure 5

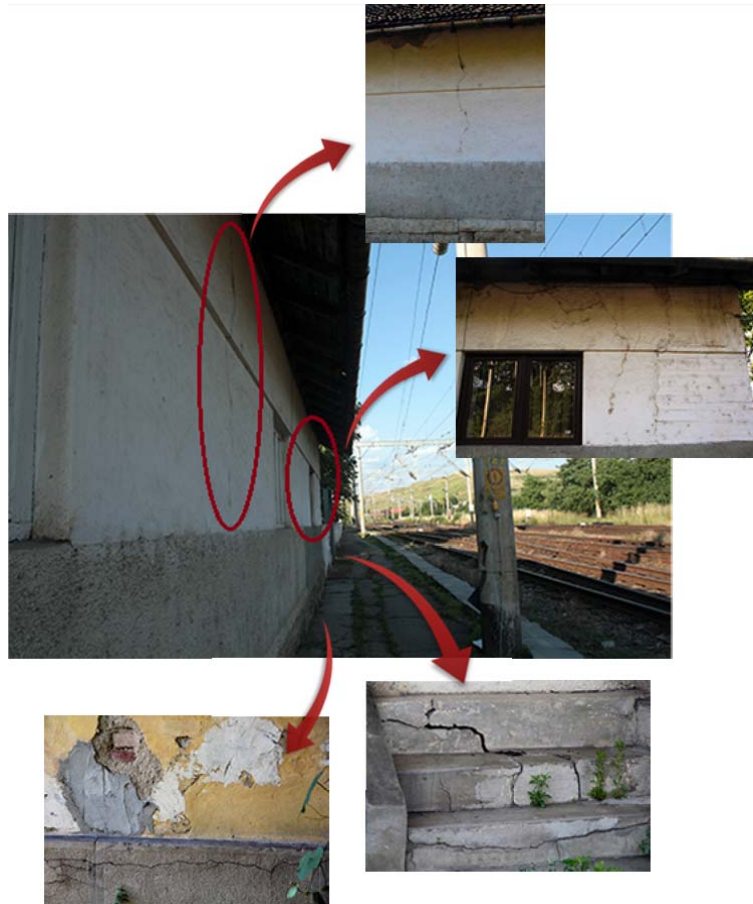

Fig. 5. Dwelling building – damage due to railway traffic

4. Conclusions

Following the measurements performed and the results, we found that the vibrations intensity level as calculated exceeds the admissible vibration intensity level. Consequently, we propose the revision of existing standards for the admissible values of vibration intensity as well as the protection against vibrations of buildings, or, is necessary, of the rolling way.

References

1. Darabonţ, A., Iorga I., Văiteanu, D., Simaschevici, H.: *Şocuri și vibrații: aplicații în tehnică (Impacts and Vibrations: Applications in Technics)*. București. Editura Tehnică, 1988.
2. Esvelt, C.: *Modern Railway Track, 2nd Edition*. Delft, University of Technology, MRT Productions, 2001.
3. Nerişanu, R.: *Studiul efectelor dăunătoare ale sistemelor de transport asupra construcțiilor (Study of harmful Effects of Transport Systems upon Constructions)* – teză de doctorat. 2014.