

BEHAVIOUR OF ELEVATED CONCRETE WATER TOWER UNDER DYNAMIC LOADS

T. MILCHIŞ¹ I. BORŞ¹

Abstract: *Loads on elevated water towers during an earthquake produce a complex stress field into structure. The mechanically differences properties of two principal materials, reinforced concrete and water are the main cause. Finite element method using coupled Eulerian-Lagrangian (CEL) model approach can provide the wanted answers. Two cases are considered in this paper. The water can freely move inside the water tower and in the other case without the movement on the water (the water is just a mass added to the structure). The conclusions are highlighted using the displacement values in the highest points of the structure.*

Key words: *water tower, Eulerian-Lagrangian model, water sloshing, dynamic analysis.*

1. Introduction

Elevated water towers are structures that generally are located in the critical points of an water-supply network, in highly populated areas in most of the cases. The main purpose is the water supply and fire safety regulations [1]. For that reason, the water towers should be fully operational during and after a major earthquake. The technical solutions for pipe joints and foundation dimension is not the main objective in this paper. Only the behaviour during a dynamic load is studied. To determine the values of maximum displacements of an water tower is the main goal.

Water towers can vary from different geometrically shapes or structural system design; truncated cone model is studied in present paper.

For soil-structure interaction problems and fluid-structure interaction a lot of mathematical models can be found in numerous papers accomplished by other researchers from various countries. A very interesting technological solution for the centre core of the tower is showed in [2], with interlocking panels. The numerical models are based on the mass adding approach with elastic resorts with different axial stiffness values that connect the added mass to the structure of the tower. A detailed analysis of an cylindrical water tower considering a free movement of the water volume (water sloshing) was done also in [3] recently in with the fluid-structure interaction is studied in detail. A more classical approach is done in [4] with the main aim to study metallic water storage where the buckling phenomenon is evaluated for that types of structures

¹ Faculty of Civil Engineering, Technical University of Cluj-Napoca, Cluj-Napoca, Romania

during an earthquake action without the considerations of dynamic load effect of the moving water in the tank. Gareane et al. [5] has made a good approximation of water tank dynamic response to earthquakes with harmonic (sinusoidal) loads patterns (artificial ground motions accelerations). The numerical simulations were made considering the adding impulsive mass to the walls of the tower.

2. Method formulation

The approach using numerical models is a highly computational time consuming for complex models. The analyses can take up to several days, even in our days, for very complex models.

In this paper we present a comparison of two numerical models using FEM with Abaqus CAE. The dynamic performance of the same water tower is analysed in hypothesis that the water has a free movement (free surface) during a lateral dynamic load; an earthquake for example, and another hypothesis in which the water volume is considered only a death load (gravity load only).

The reinforced concrete tower is considered a Lagrangian numerical model and the water volume is Eulerian model. Coupling these two models in a FEM analysis is the main issue. Thus, an Arbitrary Lagrangian-Eulerian (ALE) formulation is used for mathematical model.

Lagrangian models are based on the assumptions the material moves coupled with the mesh – the mesh points are attached to material nodes. In an Eulerian model the material moves but the mesh remains fixed – the material passes through the mesh. Mesh distortion isn't an issue for that, because the mesh never changes. For ALE the most important advantage is that an element can handle more than one material inside it [6]. A new coordinate

system is attached to the Lagrangian and Eulerian coordinates system. The material derivative relations is [7]:

$$\begin{aligned} \frac{\partial f(X_i, t)}{\partial t} &= \frac{\partial f(x_i, t)}{\partial t} + (v_i - u_i) \frac{\partial f(x_i, t)}{\partial x_i} \\ &= \frac{\partial f(x_i, t)}{\partial t} + w_i \frac{\partial f(x_i, t)}{\partial x_i}, \end{aligned} \quad (1)$$

where X_i is the Lagrangian coordinate, x_i is the Eulerian coordinate and w_i is the relative velocity. And v_i is the material velocity and u_i is the referential coordinate velocity. The ALE formulation can be expressed by the following equations:

(1) The conservations mass equation:

$$\frac{\partial \rho}{\partial t} = -\rho \frac{\partial v_i}{\partial x_i} - w_i \frac{\partial \rho}{\partial x_i}, \quad (2)$$

(2) The momentum conservation equation:

$$\rho \frac{\partial v_i}{\partial t} = \sigma_{ii,j} + \rho b_i - \rho w_i \frac{\partial v_i}{\partial x_j}, \quad (3)$$

Stress vector $\sigma_{ii,j}$ in an Newtonian fluid is:

$$\rho \frac{\partial v_i}{\partial t} = \sigma_{ii,j} + \rho b_i - \rho w_i \frac{\partial v_i}{\partial x_j}, \quad (4)$$

Boundary conditions relations are:

$$\begin{aligned} \sigma_{ii} n_j &= 0 \\ u_i &= u_i^0. \end{aligned} \quad (5)$$

On free boundary Γ_1 is the first condition from Eq.(5) and the second one in Γ_2 which represent the constrain boundary

on velocity u_i^0 . The normal vector on the traction free boundary Γ_1 is represented by η_j .

(3) The total energy conservations equation:

$$\rho \frac{\partial E}{\partial t} = \sigma_{ii,j} + \rho b_i v_i - \rho w_i \frac{\partial E}{\partial x_j}, \quad (5)$$

where ρ is the material density, b_i is the body force and E is the energy.

A numerical model was created with Abaqus/Explicit. Explicit dynamics is a mathematical technique for integration of the equations of motions through time. Abaqus explicit has the capability to solve a variety of problems: high speed dynamics for short period of time (drop test and crash), quasi-static analysis with high nonlinearities (deep drawing, assembly simulations), coupled temperature-displacement (heat transfer), structural acoustic. For wave propagation is the recommendable choice.

The dynamic equilibrium equations are simplified written:

$$M\ddot{u}^{(t)} = P^{(t)} - I^{(t)}, \quad (6)$$

where $M\ddot{u}$, P , and I are inertia force vector, applied force vector and the internal force vector from stress field.

Nodal accelerations can be easily obtained from relation (6):

$$\ddot{u}^{(t)} = [M]^{-1} (P^{(t)} - I^{(t)}). \quad (7)$$

Sequential integration of relation (7) returns the velocity and displacement vector, $\dot{u}^{(t)}$ and respectively $u^{(t)}$. An obvious advantage of explicit procedures is that no iterations are required in the equation solver for the accelerations,

velocities and displacement vectors values. The solution becomes unstable (diverge) if the time increment is too big. An estimation of stable time value can be considered by:

$$\Delta t = \min \left(\frac{L^e}{c_d} \right), \quad (8)$$

where L^e is the characteristic length of the element and c_d is the dilatational wave speed of the material:

$$c_d = \sqrt{\frac{E}{\rho}}. \quad (9)$$

Decreasing L^e values reduces the stable time increment, thus the total time necessary to complete the analysis decreases significantly.

Relation (6) is applied to any physical model with highly nonlinear behaviour. A set of nonlinear equilibrium equations are solved at each time (t) increment. Time incrementation can be done in two ways: automatic time incrementation – automatically adjustment of stable time increment during the analysis and fixed time incrementation – a constant time increment is used.

3. Numerical models

Geometry of reinforced concrete water tower is: 41m total height. The shaft has 30m in height. Maximum diameter of the reservoir is 30 m. Thickness of the wall's shaft is 40 cm and the reservoir wall is 30 cm. In Figure 1 the geometry of the model is presented.

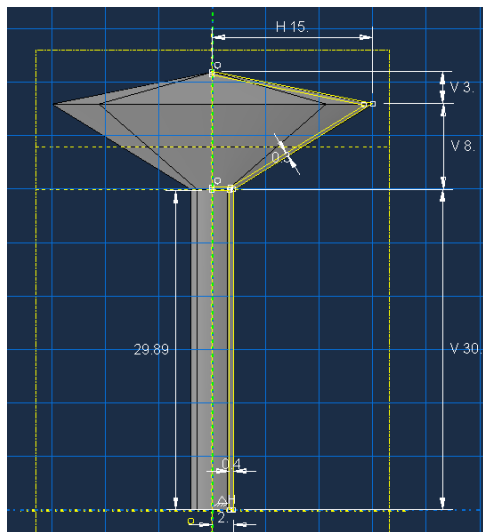

Fig.1 Water tower geometry

Two cases were considered. In the first model, the water volume is considered to be a dead load. Thus, only a static pressure is considered to the walls of the tower reservoir.

In the second model, the water volume is considered to be able to move freely inside the reservoir.

In the first model only solid finite elements were used in Abaqus type C3D10M; a 10 node modified quadratic tetrahedron. The material is a reinforce concrete with mass density 2500kg/m^3 , Young modulus $3e10\text{ N/m}^2$, Poisson coefficient 0.3.

A dynamic load is considered trough an acceleration diagram inserted as a tabular values representing the ground accelerations, recorded in 1977 – Vrancea earthquake. The total time is 40.14 seconds. Thus, a time-history analysis type has been done. The amplitudes of the acceleration diagram are modelled as a boundary condition (displacements) at the base of the tower [8].

In the second model, where the ALE is used, the water volume is considered to be able to freely move inside the tower recipient. An Eulerian domain it is defined

to achieve this. The water volume occupies approximately three quarters of the total volume of the recipient. Volume that isn't occupied by water is consider a void volume (no material definition). Suspended water reservoirs have a minimum volume of water inside then necessary for extinction of possible fires. Analysing an empty reservoir isn't a plausible hypothesis. The most interested case is when the volume of water is at the maximum level of service.

For the mast and the reservoir of reinforce concrete the same finite element type was used, C3D10M – Lagrangian domain, which is the only type that can be coupled with an Eulerian domain.

The water volume was modelled using the linear $U_S \cdot U_P$ Hugoniot form of the Mie-Gruneisen equation of state (EoS). Material parameters for the water are showed in Table 1 :

Parameters for water material Table 1

Parameter	Value
density	100 [kg/m ³]
viscosity	1e-3 [Ns/m]
c_0	1483 [m/s]

The coefficient c_0 represent the speed of sound of the material, in our case, water. The speed of sound of the fluid is inversely proportional to the fluid's compressibility. For nearly incompressible fluids, using the physical compressibility is highly computational expensive. The speed of sound is infinite in an incompressible fluid. Decreasing the value of the speed of sound will increase the stable time increment value, but will increase the compressibility of the fluid, which is not recommendable.

A various physical experiments that involves fluids can be numerically simulated. The large domain in witch the Lagrangian-Eulerian coupled approach has been used confirm this.

4. Results and discussion

Numerically studies have been done, considering two models, described in the above paragraph. A time-history analysis type was done, considering the same accelerations values for the ground motion.

In the first numerical model, more simple, the water volume in the tower reservoir is considered a static load, thus, only a static pressure is take into consideration. The node location on the tower geometry is shown in Figure 2.

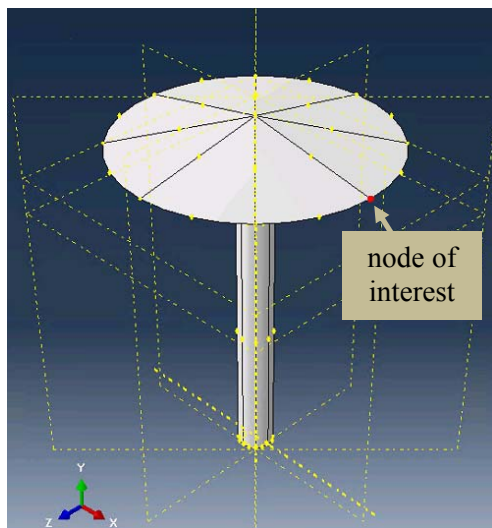

Fig.2 Node displacement that is studied

The node is situated in the most right side of the reservoir on de direction of the load vector.

The mesh density in the contact zones and the loss of material are the true problems in an numerical model. A highly dense mesh is very costly in computational terms. The ratio of deformation speed of material to wave speed is one of the most important parameters in solving the mathematical problem. Errors can appear during the analysis. Mesh refinement is a solution, but it doesn't guaranty a successful finished job.

The results consisting in he values of

displacements values on direction x is showed in Figure 3.

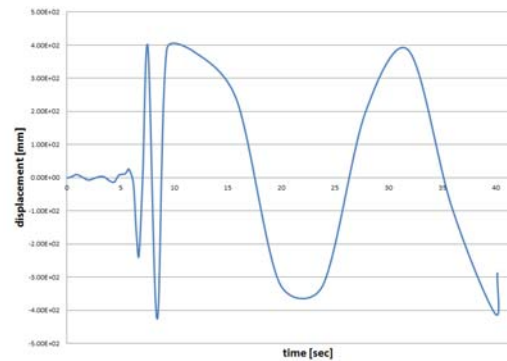

Fig.3 Displacement values (Lagrangean)

For the same geometrical and mechanical proprieties, only that in the second case the water volume is modelled using an Eulerian numerical model, the values of displacements of the same node are revealed in Fig.4.

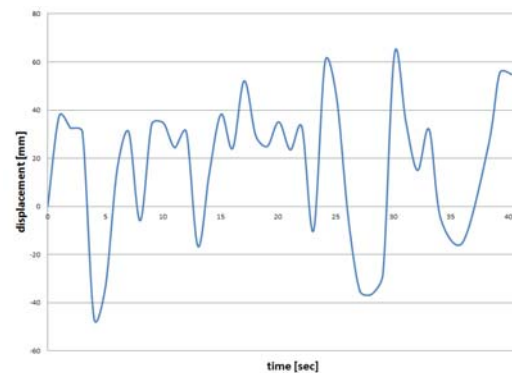

Fig.4 Displacement values (Eulerian)

It is easily to observe that the amplitudes of horizontal displacements have lower values in case of model two confronted with model one. The different variation of displacement vectors are very different. The main cause for this is the eigenvectors of the dynamic proprieties from the tower.

The acceleration diagram is showed in Figure 5.

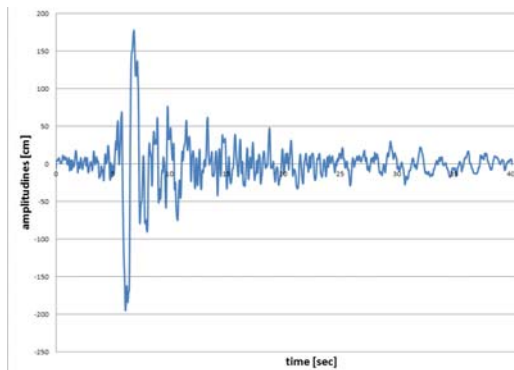

Fig.5 Accelerations values (Vrancea 77)

4. Acknowledgements

The authors grateful to prof. C. Chiorean and his research team for their support from the department of Structural Mechanics - Faculty of Civil Engineering from Cluj-Napoca.

5. Conclusions

For complex models, in which Lagrangian approach can easily fail, the coupled Lagrangian-Eulerian model is the key solution. For fluid flow problems is highly recommendable. The results accuracy using and Eulerian model is slightly less than a Lagrangian one, but we can say that the compensations can bypass those gaps.

References

1. Pîslăraşu, I., Rotaru, N., Teodorescu, M.: *Alimentări cu apă (Water supply)*. Bucureşti. Editura Tehnică, 1981.
2. Gurkalo, F., Poutos, K.: *Dynamic Properties of Watertowers Assembled from Interlocked Panels under Different Loading Conditions*. International Journal of Engineering and Technology, 4(5), 649–652, 2012.
3. Sarokolayi, K., Navayineya, B., Hosainalibegi, M., Amiri, V.: *Dynamic Analysis of Water Tanks With Interaction Between Fluid And Structure*. The 14th World Conference on Earthquake Engineering, Beijing, 2008.
4. Malhotra, P.,K., Wenk, T., Wieland, M.: *Simple Procedure for Seismic Analysis of Liquid-Storage Tanks*. Structural Engineering International, vol. 2, pp. 197-201, 2000.
5. Gareane,A.,I., Algreane, G., A., Osman, S.,A., Karim,O., and Kasa, A.: *Study the Fluid Interaction due to Dynamic Response of Elevated Concrete Water Tank*. Australian Journal of Basic and Applied Science, vol. 5, no. 9, pp.1084-1087, 2011.
6. Souli, M., Ouahsine, A., Lewin, L. : *ALE formulation for fluid–structure interaction problems*. Comput. Methods Appl. Mech. Eng. 190, 659–675, 2000.
7. Zhao, C., et al., *FSI effects and seismic performance evaluation of water storage tank of API1000 subjected to earthquake loading*. Nucl. Eng. Des. (2014)
8. Chira, A., Buru, M.: *Analiza neliniară a structurilor (Nonlinear analysis of structures)*. Cluj-Napoca. Editura U.T.Press, 2014.