

ANALYSIS OF GEOTECHNICAL CONDITIONS FOR CONSTRUCTION OF DESULPHURIZATION OF THERMAL POWER PLANT UGLJEVIK 1

N. ĐURIĆ¹

Abstract: *As part of the project environmental protection for consequences of broadcasting polluting particles from previously constructed power plants, provides the construction of new plants, which are an integral part of the existing facilities. For existing Power plant Ugljevik 1, built in the eighties of the twentieth century, it is planned the construction of plants for flue gas desulphurisation, which in its complex has several significant buildings. Taking into account the complexity of geological settings, at the location of plant construction and the importance of the objects geomechanical field research and analysis of geotechnical conditions foundations of future facilities were performed*

Key words: *field exploration, geological environment, foundation objects*

1. Introduction

Construction of flue gas desulphurization, is related to a project of purification of previously constructed power plants. The plant consists of a complex of different buildings in importance and dimensions. It will be located next to the existing power plant 1, and after its construction it will make a unique complex of thermal power plant Ugljevik 1.

Due to the complexity of the geological structure of the field, determined by earlier studies, geomechanical study of space were carried out. There is a possibility that at a later stage in the determination of the exact location of the facilities, research and

focus on specific micro-locations would expand.

The construction of desulphurization plant, will improve the environment in the region, given that TPP Ugljevik 1, has the greatest impact on the northeastern part of Republic of Sprpska and Bosnia and Herzegovina. It should be noted that in this region, in addition to these power plants, is registered the impact of power plant Tuzla and Obrenovac. But the biggest impact has TPP Ugljevik 1, which the project plant gives more importance.

¹ Faculty of Civil Engineering Subotica, University of Novi Sad

2. Main geological characteristics of the field

Natural terrain morphology is partially modified during the construction of the previous power plant. Relocated are the riverbeds of and Mezgrajica and depression are filled with a filled material. The whole area is a flat surface. The terrain is characterized by frequent changes in the lithological composition of the smaller space. Therefore, they needed a more detailed study, given the importance of the facilities to be constructed.

For a fuller consideration of the characteristics of the field, previous studies, which are at a high level were analyzed. For a fuller consideration of the characteristics of the field, analyzed previous studies, which were at a high level. Previously done basic geological map OGK Yugoslavia 1: 100000 with an interpreter [1] and geotechnical field explorations for an existing power plant, gave a clear picture of the natural

morphology of the terrain, the lithological composition and structural-tectonic relations. The current research is based on previous research, and the continuation of further research for a more detailed consideration of the characteristics of the field. Engineering geological mapping of the terrain and the surrounding area is a precursor to the exploration activities. Registered offshoots rocks are present on the surface and placed typical geological profiles in which are made exploration wells. Coring was performed in its entirety, and on nucleus were observed lithological changes and correlated with data obtained by mapping the field. Experiments of SPT, and the results of laboratory tests on samples from individual lithological, completed a picture of the geological structure of the field and geomechanical properties of the individual layers. It is done totally eight (8) boreholes to a depth 25.0 m, figure 1, from each lithological change, samples were taken for laboratory testing.

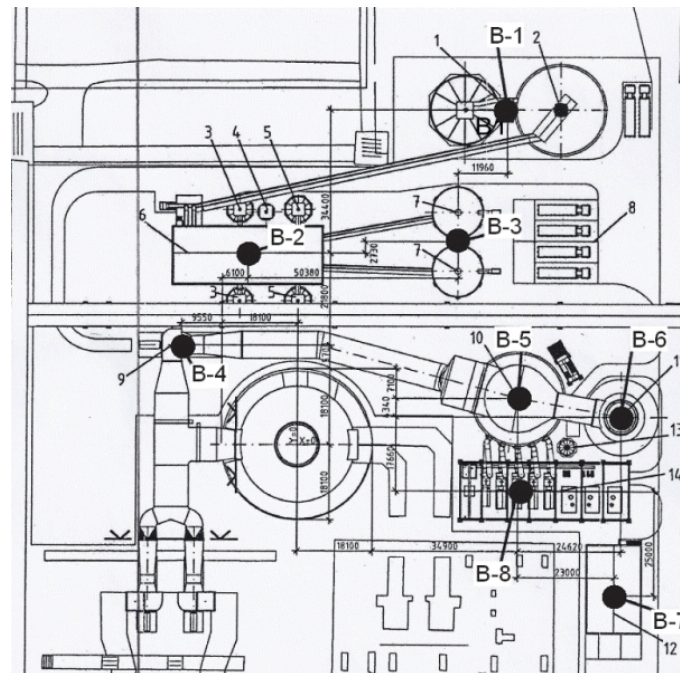

Fig. 1. Position of exploratory boreholes in relation to the structures of plants

On the ground are separate two types of relief, fluvio-storage as a plain type and erosion-denudation as mountain type. Of surface flows, which have an impact on researched location, there are natural and regulated river flows Janja and Mezgrajica. Former riverbed of Janja provided the central part of the plateau [2].

The structure of the ground from the surface to a depth of research part are of the Quaternary sediments and Tertiary age

[2],[3]. The order of sediments determined by age is as follows:

Paleocen – eocen sediments (P_c , E_1), build up the slope west of the existing thermal power facilities, while on micro-location of the studied field built the lower horizons of the substrate at depths of 8.0 to 18.0 m. They are presented with the sediments of marl, shale and sandstone, figure 2.

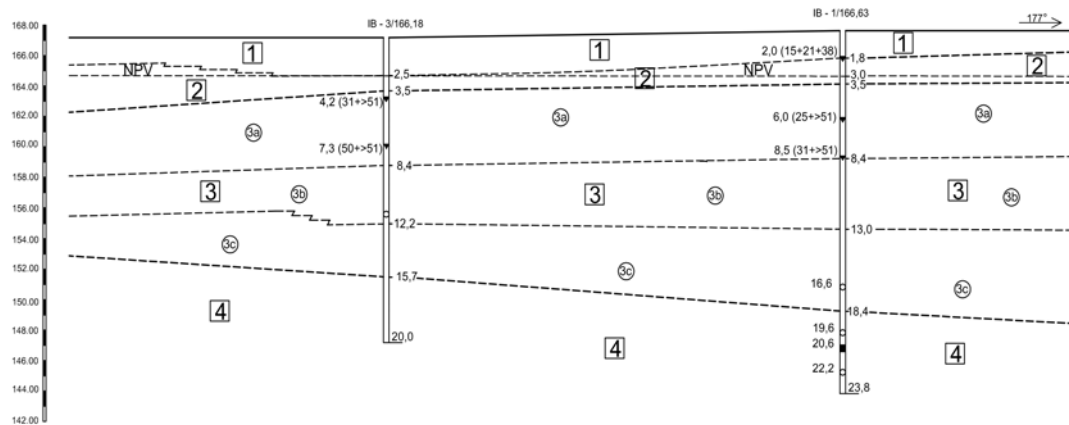

Fig. 2. Geological profile of the terrain
 1 and 2. River alluvial sediments(al), 3. Neogene sediments ($^1M_1^1$), 4. Peleocen-eocen sediments (P_c , E_1)

Neogene sediments, the Lower Miocenestarosti ($^1M_1^1$), build a higher Horizon into the substrate, and are represented by conglomerates, sandstones, gravelly and sandy sediments and clayey-sandy marl with lenses of marl clay. Sediments form a complex that is often dismissed in horizontal and vertical direction, because they were created at the time of lake sedimentation. They are registered at depths 3.5 – 6.0 m.

River alluvial sediments (al), built the near surface parts of the field. Represented are with the typical development of river sediments in which the lower part of the deposit

consists of gravel and the sandy beach and the upper part of the fine-grained sediment flooded. The thickness of the sediments is from 1.5 – 4.2 m

3. Analysis of geotechnical conditions construction

For the analysis of geotechnical conditions of design and construction plant for flue gas desulphurisation of TPP Ugljevik 1, it is done a detailed structural analysis of the field in relation to the lithological types of soils, their position within the studied depth of field as well as their relative position, and their condition, composition, engineering and hydrogeological characteristics and physical -

mechanical properties and resistance - deformable features [4]. For the purposes of detailed insight into the structure, based on the results of field and laboratory research and testing it has been done more graphics, terrain modeling, depending on the importance and location of the object classes.

Ground plant for flue gas desulphurisation of TPP Ugljevik 1, up to depth, 25.0 m, build sediments - lithological members of various physical - mechanical and resistance - deformable characteristics. A detailed analysis of lithological parameters, identifies four (4) geological environment within which the conditions or load shedding, behave identical or similar.

The choice of parameters within the geological environment, relevant for geostatic calculations is done on the basis of:

- results of laboratory tests of samples of soil and rock solid, taking into account the level of representation and test conditions
- data on the actual properties of the rock mass marl complex and complex sandstone (lithological heterogeneity, structural - textural properties, the degree of cracking and crack characteristics, the degree of surface degradation, as well as other important observed characteristics)
- existing empirical correlations between the physical and mechanical properties, structural properties and rock mass rating (Analysis of Rock / Soil Strength using RocLab).

Geological environment 1, it is built in Quaternary sediments and alluvial deposits. The complex consists of alluvial sediments: clay (1a), sands (1b) and gravels (1c). Thickness goes up to 2.7 m,

and the area of the former river Janja to 4.2 m. Continuously spread out except in the western part of the field around the borehole IB – 6. Most are represented by gravel and sand in layers of varying thickness which rotate vertically and laterally, the water bearing.

The entire complex of alluvial sediments can be treated as an environment with characteristics of bars environment that is under load behaves elastically up to brittle plastic [5],[6]. The adopted parameters for geostatic calculations are as follows:

Clay CL – CH – 1a

- Bulk density $\gamma = 19.75 \text{ kN/m}^3$
- angle of internal friction $\varphi = 18^\circ$
- cohesion $c = 29 \text{ kPa}$
- compressibility module $M_s \text{ (100- 200)}$
 $= 4 \text{ 838 kPa}$

Sand SW – SC – 1b

- Bulk density $\gamma = 19.00 \text{ kN/m}^3$
- angle of internal friction $\varphi = 26^\circ$
- cohesion $c = 0 \text{ kPa}$
- compressibility module
 $M_v = 13 \text{ 000 kPa}$

Gravel GW – 1c

- Bulk density $\gamma = 18.36 \text{ kN/m}^3$
- angle of internal friction $\varphi = 38^\circ$
- cohesion $c = 0 \text{ kPa}$
- compressibility module
 $M_v = 40 \text{ 000 kPa}$

Loose part of environment 1, is suitable for shallow building foundations, if the groundwater is at a depth of 1.5 to 3.0 m.

Geological environment 2, is build of sediments of bark spending substrate field, represented as clay marl with debris (2a), clayey sand with debris (2b) and clayey gravel with debris (2c). It is formed by the process of degradation of the substrate surface paleorelief field. Continuously spread apart in the northwestern part of the area around the borehole IB – 7. The thickness of the sediments bark

spending is variable, and is usually from 0.8 to 1.4 m where clay marl with debris has the largest share.

Complex of sediments of bark spending can be treated as an environment with characteristics of loose environment that is under load behaves from elastically up to krtoplastično. The adopted parameters for geostatic calculations are as follows:

Clay CL – CH – 2a

- Bulk density $\gamma = 19.5 \text{ kN/m}^3$
- angle of internal friction $\varphi = 20^\circ$
- cohesion $c = 26 \text{ kPa}$
- compressibility module $M_s \text{ (}_{100-200}) = 4\,228 \text{ kPa}$

Sand SW – SC – 2b

- Bulk density $\gamma = 19.3 \text{ kN/m}^3$
- angle of internal friction $\varphi = 29^\circ$
- cohesion $c = 0 \text{ kPa}$
- compressibility module $M_v = 11\,000 \text{ kPa}$

Gravel GC – 2c

- Bulk density $\gamma = 19.3 \text{ kN/m}^3$
- angle of internal friction $\varphi = 39^\circ$
- cohesion $c = 0 \text{ kPa}$
- compressibility module $M_v = 40\,000 \text{ kPa}$

Loose part of the environment² is suitable for shallow building foundations, if the groundwater are at a greater depth. The computational part included the presence of groundwater, but the run-time object should adjust the time period when the groundwater level may be lower.

Geological environment 3, belongs to a higher complex rocks into the substrate. Build a soft fine clastic rocks

- Bulk density $\gamma = 24.25 \text{ kN/m}^3$

of marl-sandy-clayey and soft large clastic rocks: sandstone marl, marl conglomerate with sandstone with cm strips. In this environment have been included the complex-modified layers, decimeter dimensions, sandstone, conglomerate, marl and complex centimeter layer of clay marl, marl, clayey marl and sandstone.

Extent of environment 3, is characterized by different depth of occurrence and its mightiest, which ranges from 5.8 to 24.8 in the part of the borehole IB – 2. The highest representation in the bottom 3 have large clastic rocks sandstone of marl and marl conglomerates that alternate in the vertical column with an occasional side of removal. Within these two dominant members appear interbeds of limited spreading and lenses of fine clastic sediments of marl-clay-sandy soils within which occasionally observed smaller lenses marl clay.

Observed gradation of clastic sediments and relative rhythmic changes of layers gives the middle 3 characteristic of flysch in which they developed partial sequences with frequent lateral changes. Rocks of the area are quite broken, cracks usually rough and altered, usually filled with clayey-sandy material.

Dominantly environment 3 has properties of brittle environment. Subordinate layers of marl and shale rocks have the characteristics of quasi-plastic protection, which was adopted following parameters:

	Intact rock	Converted into massiv
▪ angle of internal friction	$\varphi = 29.33^\circ$	$\varphi = 29.33^\circ$
▪ cohesion	$c = 0.81 \text{ MPa}$	$c = 0.133 \text{ MPa}$
▪ compressive strength	$\sigma = 3.57 \text{ MPa}$	$\sigma = 0.225 \text{ MPa}$
▪ modul of elasticity	$E = 8212 \text{ MPa}$	
▪ Poisson's ratio	$\nu = 0.210$	

Characteristics of this environment are such that generally make a favorable environment for building foundations.

Geological environment 4, build rocks marl, marl with layers of sandstone thickness mm to cm. This community belonging and marly clay, which occur in the form of larger lenses.

Cracking rocks in this environment is expressed. Prevail the cracks along the bedding plane, rough walls, mostly clenched. It is also observed and cracks whose corners falls ranging from 45°

to the subvertical. The walls are rough to smooth, spaced. In the upper zone, closer to povlatnim conglomerates and sandstones, cracks are often filled with fine sand.

The entire complex of marly rock of environment 4 has the characteristics of quasi-plastic environment, to a lesser extent of the plastic in which the most common marl are soft rocks of moderate strength and formability. The adopted parameters for geostatic calculations are as follows:

▪ Bulk density	$\gamma = 24.29 \text{ kN/m}^3$	
	Intact rock	Converted into massiv
▪ angle of internal friction	$\varphi = 33.68^\circ$	$\varphi = 25.70^\circ$
▪ cohesion	$c = 1.19 \text{ MPa}$	$c = 0.182 \text{ MPa}$
▪ compressive strength	$\sigma = 4.42 \text{ MPa}$	$\sigma = 0.222 \text{ MPa}$
▪ modul of elasticity	$E = 11002 \text{ MPa}$	
▪ Poisson's ratio	$\nu = 0.240$	

As an environment for foundations of buildings is a convenient medium. Due to its depth of occurrence, it is realistic to expect that they will be based deep - pile, where the facilities for larger loads permitted payload can solve the diameter and length of the pile.

4. Geostatic budgets for foundation of objects

Plant flue gas desulphurization TPP 1, consists of 14 buildings of different sizes and importance. For the purposes of shallow and deep foundations, calculations were made for geostatic capacity and settlement facility [7], [8].

• Shallow foundation of buildings

For facilities to be shallow substantiated, are proposed foundations with the shape of the continuous strips at a depth of 2.5 m from the ground

surface, a width of 2.0 m. Shallow foundations are shown through geological environments: 1a, 1b, 1c, 2a and 2b. The results are shown in table 1.

Results for shallow foundation of objects

Table 1.

Label od the environment	Allowed burden(kPa)	Subsidence central point of the foundation in(cm)
1a	362.75	1.691
1b	244.58	0.887
1c	676.17	3.882
2a	321.03	1.418
2b	819.69	4.880

Maximum differential settlement. at allowable burden is:

$$4.880 - 0.887 = 3.93 \text{ cm}$$

It can be concluded that the differential settlement is not great and that the difference in subsidence reduced. because of the initial subsidence.

Shallow foundations can be applied to objects that are on the ground or high up to one floor.

• Deep foundations of buildings

Deep-founded grounds. is considered foundations on bored piles with lengths

AB 15.0 and 25.0 m. Diameter of the pile is 0.6 m. The analysis was performed for:

- 1 pile single length 15.00 m
- 4 piles in group length 15.00 m
- 1 pile single length 25.00 m
- 4 piles in group length 25.00 m

Results for capacity calculation and settlement of piles of length 15.0 and 25.0 m, as well as for single pile and pile group 4 pieces, are given in table No. 2.

Results for deep foundation of objects

Table 2.

Length of pile (m)	Single pile	Group of four piles	Load of pile (kN)	Subsidence (cm)
15	1	-	4355.78	1.489
15	-	4	17423.14	3.628
25	1	-	4282.30	0.038
25	-	4	17.129.20	0.108

Deep foundations can be applied to objects larger loads, which will define

he design solution of the planned system.

5. Conclusion

In order to reduce environmental pollution, for the existing power plant Ugljevik 1, the construction of plants for flue gas desulphurisation is planned. The complexity of geological settings, demanded his preliminary examination to the construction of the plant. Conducted are field research and laboratory testing, and performed correlation of data from previously conducted research for the purpose of TE Ugljevik 1.

The analysis of geotechnical conditions of design and construction of buildings was found that land for the future power plants is built of four (4) environments in depth and horizontal, pointing in different field terraces - alluvial plains and the hillside part of the exploration space. Within each of them, all of the lithological members in conditions of load or relief behave the same as or similar. For each isolated community are adopted parameters for geostatic calculations.

For objects of plant flue gas desulphurisation Ugljevik 1, can be applied shallow and deep foundations. Shallow foundations refers to the single-storey building or the highest building with one floor. Deep foundations related to the AB piles, length of 15.00 and 25.00 m, diameter 0.6 m.

References

1. Čičić, S., Mojičević, M., Jovanović, Č., Tokić, S., Dimitrov, P. (1980). Osnovna geološka karta, OGK list Tuzla 1:100000. Beograd. Savezni geološki zavod.
2. Đurić, N., Mitrović, P., Perišić M. Elaborat o geomehaničkim istraživanjima terena za projektovanje i izgradnju Postrojenja za odsumporavanje dimnih gasova u TE Ugljevik 1. Ugljevik. Bijeljina. Tehnički institut. (2013).
3. Đurić, N., Đujić, A., Babajić, A., Srkalović, D., Tadić, S., Perišić M. Geološke karakteristike terena na lokaciji Termoelektrane Ugljevik 3 u Ugljeviku. Jahorina Pale. V. savjetovanje geologa Bosne i Hercegovine sa međunarodnim učešćem. Jahorina Pale. Zbornik radova CD. (2013). str. 473-483.
4. Đurić, N., Đuran P., Miljanović J. Laboratory testing of samples at the location of the Thermal Power plant – Ugljevik 3. Bijeljina. Zbornik radova „Arhiv za tehničke nauke“ br. 9, Tehnički institut. (2013). pp. 15-23.
5. Santrač, P. “Interaction of Close Foundations”. Yearbook of the Faculty of Civil Engineering Subotica. (2000). No. 12. pp.106-114.
6. Đurić, N. Hidrogeološka i inženjerskogeološka istraživanja. Subotica, Bijeljina. Građevinski fakultet, Tehnički institut. (2011).
7. Bowles, J.E. Foundation analysis and Desing. Fifth edition. Mc Grav-Hill. (1996).
8. Maksimović, M. (2005). Mehanika tla, treće izdanje. Beograd. Građevinska knjiga. (2005).