

INTEGRATION OF AD HOC WIRELESS SENSOR NETWORKS IN A VIRTUAL INSTRUMENTATION CONFIGURATION

Mihai MACHEDON-PISU¹

Abstract: *By using wireless sensor networks for monitoring and control applications, data acquisition systems can be implemented remotely with reduced complexity. In this paper, the possibility of developing acquisition systems through ad hoc type networks using a star topology will be discussed. An application is developed with virtual instrumentation software for acquiring and controlling the temperature. This implementation shows that developing applications for remote monitoring and control can be easily achieved with ad hoc networks.*

Key words: *ad hoc network, star topology, wireless sensor networks, data acquisition systems, virtual instrumentation.*

1. Introduction

Wireless (radio) communications can be seen as a viable alternative to traditional cabled communications. For example, in very narrow areas and polluted environments, such as industrial halls, a wireless approach can be considered more appropriate.

With the new wireless standard: ZigBee [8], which is destined for monitoring and control applications, it is possible to elaborate data acquisition systems with *minimal power consumption* and *reduced complexity* using communication devices whose costs are small and without the need to develop an infrastructure, as in wired systems. Concurrently, an acquisition system based on wireless technologies presents disadvantages.

For example, the data rate for ZigBee is only 250 kbps, so little data can be

transmitted in a very short time. Also, the coverage (connectivity) is bounded by the distance between nodes, the propagation conditions and the level of interference in that environment. The lifetime of wireless networks is also limited. Another problem is related to the packet error rate (PER). Due to great values in case of wireless communications, wireless systems are considered unreliable and uncertain, unlike the wired systems.

To implement wireless acquisition systems, the ad hoc networks will be considered in this regard. The aim is to obtain optimum data transmissions in terms of reduced complexity. Also, for meeting the requirements of industrial applications, the interoperability with wired communication structures will be considered by providing an interface based on virtual instrumentation.

¹ Dept. of Electronics and Computers, *Transilvania* University of Braşov.

Saving power and reducing costs are important features when implementing ZigBee in industrial applications. Among these features one should include: - very short duty cycle; - strict management of power; - small waiting time; - relatively small transmit power at output; - modulation scheme with limited requirements on SNR ratio; - loose spacing between channels etc.

2. Ad Hoc Wireless Networks in Star Topology

The wireless sensor networks (WSN) [4], created by connecting sensor nodes, can use any of the following topologies: star, hybrid star and mesh. Figure 1 shows the architecture of these network topologies. The star topology is the least complex. It allows operation of edge nodes (powered from batteries) with very low power. The hybrid star topology is similar to the proposed architecture of ZigBee and also allows operation of edge nodes with very low power.

Compared to star topology, the hybrid star network has more routing nodes (powered from the power line), connected to the main power line. It also has a much wider coverage. The mesh topology [1] represents a more special type of ad hoc network, which is self-forming and self-regenerating. For this network, the reliability and lifetime are maximal.

For operating nodes with low power in mesh networks time synchronization is required. The mesh network is also the most scalable.

The basic characteristics of sensor networks and ad hoc networks are synthesized in Table 1 [2]. However, there are obvious similarities that do not appear in Table 1.

Most wireless sensor networks use an ad hoc network architecture, which can be seen as a collection of wireless nodes,

possibly mobile, which can self-configure to form the network without requiring the existence of an infrastructure [3]. The mobile nodes participate in the network in a distributed fashion.

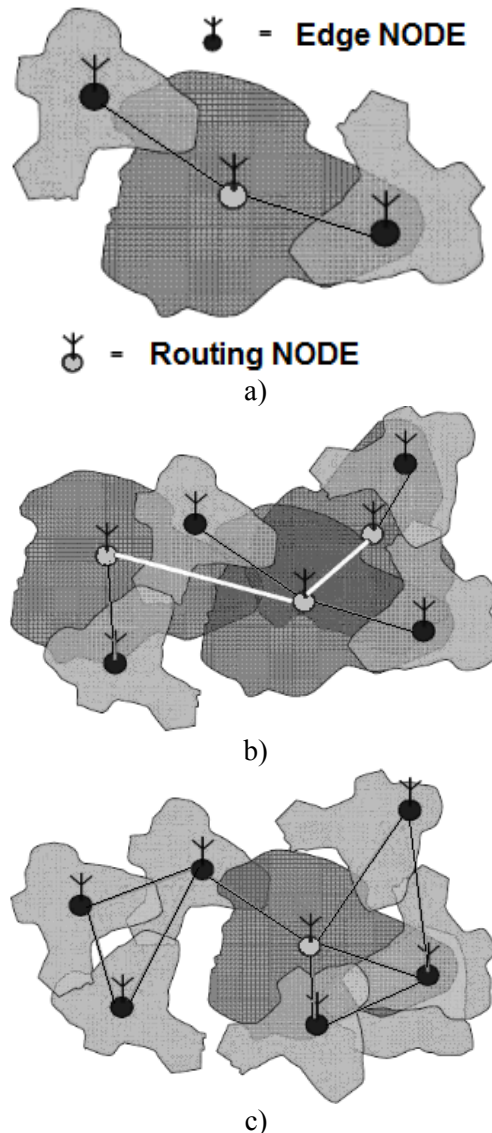

Fig. 1. *Network topologies: STAR (a), HYBRID STAR (b), MESH (c)*

Ad hoc architecture is very attractive for sensor networks for several reasons:

- ad hoc architecture outperforms the difficulties that a predetermined infrastructure

Wireless sensor networks versus ad hoc wireless networks

Table 1

Basic characteristic	Sensor networks	Ad hoc networks
Number of nodes	Large; hundreds to thousands (up to 65000)	Small or medium (a few to tens)
Nodes density	High (can be lower than 1 meter)	Relatively low (tens to hundreds of meters)
Data redundancy	High	Low
Power	Non-rechargeable batteries	Rechargeable or replaceable batteries
Transfer rate	Low; up to 100 kbps	High (up to a few or tens of Mbps)
Nodes mobility	Low	High
Direction of flows	Predominantly unidirectional	Bidirectional; end-to-end flows
Packets forwarding	Many to one; data centric	End-to-end address centric
Query nature	Based on attribute	Based on node
Addressing	No globally unique ID	Globally unique ID
Active duty cycle	Can be reduced, as low as 1%	High (higher than 20%)

infrastructure could raise for other wireless networks. Sensor networks can be developed and reconfigured quickly and randomly: new nodes are added on request to replace damaged or disconnected nodes and existing nodes can leave the system without affecting the functionality of the nodes;

- ad hoc networks can be easily integrated in specific applications;

- this architecture is very robust in case of node failures and provides a high level of tolerance to failures due to the redundancy of nodes and to the distributive nature of the network;

- energy efficiency can be improved through multi-hop communications: power can be saved by choosing a multi-hop path over short distances instead of a one hop path over a long distance to the same destination;

- ad hoc networks have the advantage of bandwidth reuse that also benefits from dividing the long-distance single hop into short-distance hops.

Although sensor networks are based on multi-hop ad hoc architectures, however, due to the unique requirements of target

applications, sensor networks are different from typical ad hoc networks. As a result, the architectures and protocols for ad hoc networks cannot be extended to sensor networks. Therefore, a new approach is required to meet typical wireless sensor networks requirements. These differences lead to many technological challenges in the design and implementation of wireless acquisition systems.

3. ZigBee Acquisition Network with Wireless Nodes

For elaborating wireless acquisition systems, a ZigBee type ad hoc network is used, implemented with WN - Wireless Nodes modules [7]. The ZigBee standard, defined by IEEE 802.15.4, is a standard for low power (up to 9dBm) wireless networks with low transfer rate (up to 250 kbps), intended especially for monitoring and remote control applications.

The network layer of a module supports only the star topology. The WN network is made up of several hardware modules that allow the measurement or control of end

nodes through radio communications.

There are two basic categories of WN modules: - *Coordinator Node*: a router (connected to the monitoring server through the USB interface), which automatically initiates the ZigBee network formation: - *Measurement Nodes* (end modules) are acquisition systems that provide the conversion from analog to digital of parameters such as voltage and current (from different sensors) and send the result to the coordinator node.

The acquisition system connects to the Internet using a star network with various WN modules (Figure 2).

The **WN-Ethernet** module connects to an Ethernet port, allowing the network of modules which it coordinates to be accessed by a user connected to the Internet. There is also the option to permit only local access without connecting to the internet.

The **WN-USB** module is connected to the USB port, and it is useful when it is desired to "locally" access the network of modules. The output power of the modules provided with external antenna is 60 mW (at 18 dBm). This means a range up to 100 m in buildings or urban areas and up to 1.6 km in direct line of sight.

The output power of the modules without external antenna (but with built-in antenna on the chip) is 1 mW (at 0 dBm). The range is 30-40 m in buildings and urban areas and 100 m in direct LoS.

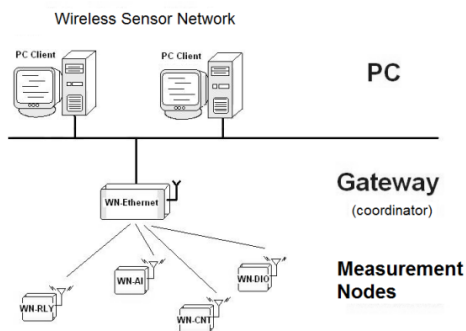

Fig. 2. Ad hoc acquisition network with *WN-Ethernet* as coordinator node

The measuring modules (to which sensors and actuators are connected) are: **WN-AI**, two-channel module for measuring analog signals (voltage in the range of ± 10 V or current in the range of 4 to 20 mA) and **WN-RLY**: C type two relay module (1 A at 30 V_{DC} and 0.5 A at 30 V_{AC}). For data acquisition from sensors, the following scenario is used: each sensor is connected to a WN-AI module, coordinated by the WN-USB module, thus designating a star WN Network for sensors (Figure 3).

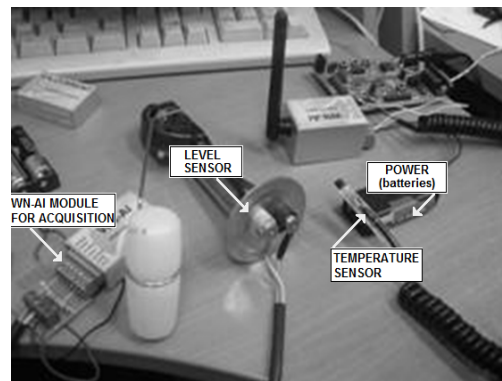

Fig. 3. Data acquisition from two sensors with *WN-AI* and *WN-USB* modules

Ad hoc networks with WN modules can be programmed and controlled both by applications written in the C programming language and by virtual instruments made in the **LabVIEW** graphical programming. Adding a node is performed by software using the **WN_AddNode** function. This function has as input variables: a keyword specifying the type of node, the **MAC address** of the end module and a name (alias) in order to recognize the module within the application.

Reading a measured value from the AI module can be done by calling a sequence of functions:

- **WN_Connect** to open a connection to the module;
- **WN_AIRead** for effectively reading measured values;
- **WN_Disconnect** to close the connection.

The WN_AIRead function has as input variables: the name of channel(s) that is/are being read, the aggregate sampling rate and the number of values read. At output, the function returns a vector in which, if both module channels were read, the readings are multiplexed.

Figure 4 shows the user interface for the acquisition program (a virtual instrument) which reads the measured value from the sensor node, WN_AIRead.vi.

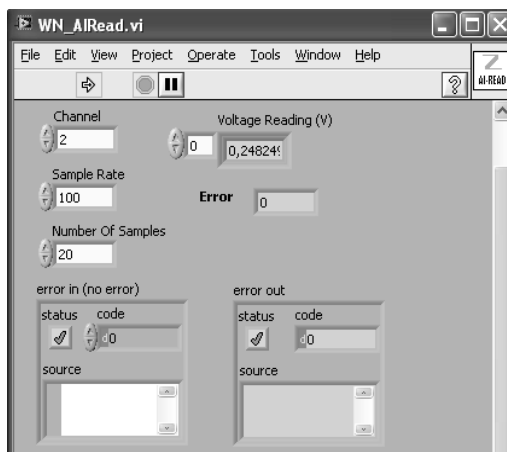

Fig. 4. User interface of the WN_AIRead program

4. Implementation of the Temperature Monitoring and Control Application

By using the virtual instrumentation software (LabVIEW) it is possible to implement monitoring and remote control applications [5].

Two temperature sensors LM35 are used for such application. The sensors are connected to one WN-AI module (Figure 5) in order to retrieve data from them. The LM35 sensor has an analog output, which means it is simple to use, plus it has low power consumption [6].

Several software functions, described previously, are used in order to contact the sensor node and read data from it:

WN_Connect, WN_AIRead and WN_Disconnect. These functions are implemented in LabVIEW.

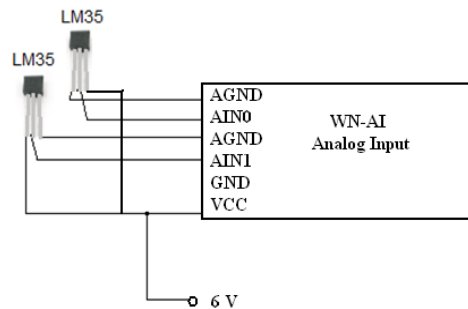

Fig. 5. Connecting LM35 sensors to the WN_AI module

WN_Connect.vi (Figure 6) is a function that opens a radio wireless connection, between the computer and WN module. WN_Connect function must necessarily be used during a communication session between the PC and the measuring WN module to begin this communication. When running WN_Connect.vi is necessary to fill in the correct node alias name, the same name that was used when the WN-AI module was configured.

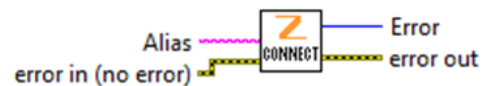

Fig. 6. WN_Connect.vi

WN_AIRead.vi (Figure 7) reads the voltage from channel zero or channel one or from both channels of the acquisition module WN-AI.

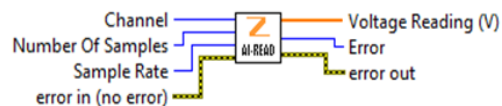

Fig. 7. WN_AIRead.vi

The sampling rate is by default 100S/sec (S = samples). The output of this block includes the voltage measured.

WN_Disconnect.vi (Figure 8) closes the open connection between the computer and the WN module. WN-Disconnect.vi function must be necessarily used during a communication session to close it.



Fig. 8. *WN_Disconnect.vi*

These functions will be included in the final LabVIEW application. The implementation of the LabVIEW program is described by the block diagram in Figure 9, which highlights the data acquisition from sensors, the conversion from voltage values to Celsius degrees values and the graphical representation of temperature variation in time for Sensor 1.

In the front panel there is a startup button that must be always in true state for data to be acquired continuously until the button is pressed. In this case, the whole application is stopped by changing the initial true state. If data acquisition must be stopped, in order to change to control, then the control button “Activate RLY” must be in true state. To get back to data acquisition, this button should be changed to the initial false state.

As can be seen in the block diagram, the waiting time is set to 30 milliseconds. This function waits the number of milliseconds specified and returns the timer value. This means it ends the program execution only after the specified time has expired. Data is read from both channels. These readings contain mean values of the samples acquired. The mathematical function MEAN is used to average the raw data (average values of input) for each channel.

Data from channels zero and one is read and displayed in real time on the front

panel by means of the Waveform Graph indicator. Once the data is acquired from the sensors, it is processed according to a specific formula, typical for the sensor used. Since LM35 sensor was used, with a conversion formula of $10 \text{ mV}/^{\circ}\text{C}$, then multiplying the input voltage value (in mV) with 100 should provide the corresponding value in Celsius degrees. These values are read in real time and displayed graphically on the front panel.

In order to achieve temperature control, a relay module will be used, which is automatically activated if the “Activate RLY” button is in true state. The WN-RLY module has 2 type C relays and two channels: RLY1 and RLY2 and both of them can take NC - Normally Closed and NO - Normally Open values. Using the four combinations (states) of this module, several conditions will be implemented in order to control the temperature:

- RLY1 is in the true state if the temperature in the room is in the optimal range. For example, the temperature can be considered optimal between 20 and 25 Celsius degrees;
- RLY1 is in the false state if the temperature is not in the optimal range;
- RLY2 is in the true state when the temperature is higher than the maximum value in the optimal range, in this case, 25 Celsius degrees;
- RLY2 is in the false state when the temperature is below 25 Celsius degrees.

The control application is shown in Figure 10. There are four conditions that can be used, as seen in Figure 11. Yet only three decisions are needed to ensure the optimal temperature range.

The WN-RLY module was configured and tested accordingly, similar to the WN-AI module. For the control application (Figure 10) the function WN_RLYSet.vi was used, as seen in Figure 12.

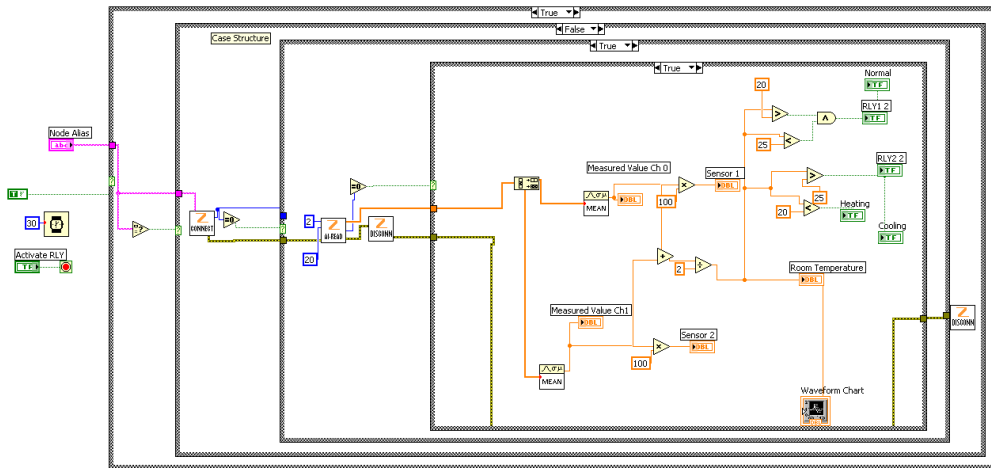

Fig. 9. Block diagram of the data acquisition application

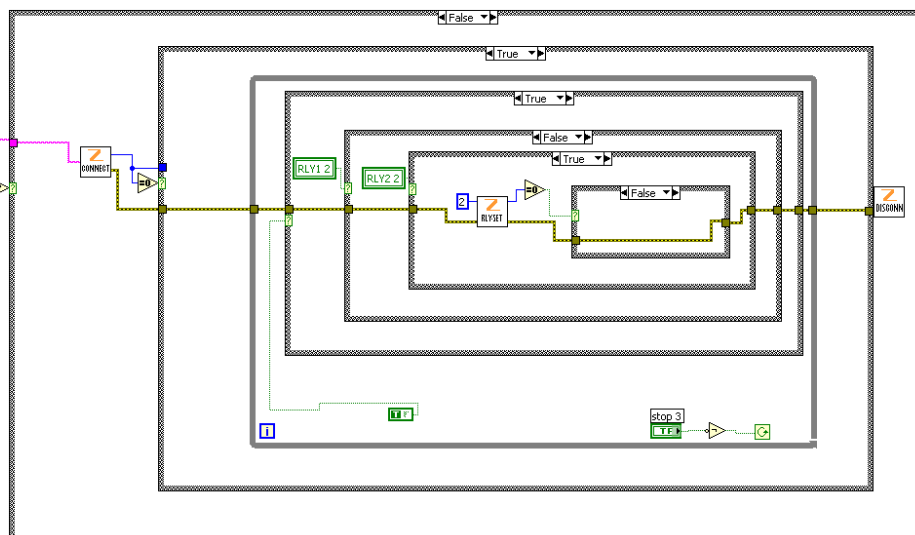

Fig. 10. Block diagram of the control application

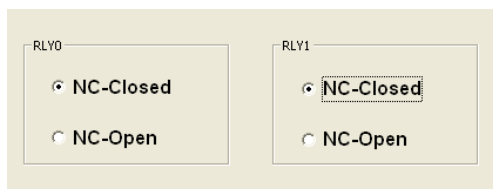

Fig. 11. *WN_RLY* four states



Fig. 12. The *WN_RLYSet* function

5. Discussion and Conclusions

While the mesh topology is more scalable and reliable than the star topology, and also permits a longer transmission distance (can be higher than 100 m), because it describes a multi-hopping system, the star topology has the lowest power consumption per node, because its nodes are within direct communication range (30 to 100 m) to the gateway.

Since WSN applications share common requirements such as: efficient hardware

and software integration, low power consumption and a robust networking protocol, our implementation based on the star topology can meet these requirements. The virtual instrumentation configuration assures the interface between software (LabVIEW program) and hardware (WN modules) with reduced complexity and low effort, as can be seen for the application developed. The networking protocol, which can be used to access the Internet, is based on globally unique IDs (MAC address plus alias) and specific sequences of functions (for example, WN_Connect, WN_AIRead and WN_Disconnect). The single-hop star topology assures less power consumption per node than the multi-hop mesh topology. Also, for extending the transmission range, WN modules are provided with an external antenna that permits an output power of 60 mW.

Due to the reduced complexity and the interface with virtual instrumentation, ad hoc wireless networks with WN modules are easy to implement for monitoring and control applications, as proven by the application developed for acquisition and remote control of indoor temperature using LM35 sensors.

Acknowledgements

This research was supported by the grant POSDRU/159/1.5/S/134378 financed from

the European Social Fund and by the Romanian Government.

References

1. Hossain, E., Leung, K.: *Wireless Mesh Networks: Architectures and Protocols*. Springer, November 2007.
2. Ilyas, H., Mahgoub, I.: *The Handbook of Ad Hoc Wireless Networks*. CRC Press, July 2004.
3. Ilyas, M.: *The Handbook of Ad Hoc Wireless Networks*. CRC Press, December 2002.
4. Karl, H., Willig, A.: *Protocols and Architectures for Wireless Sensor Networks*. Wiley-Interscience, October 2007.
5. Park, J., Mackay, S.: *Practical Data Acquisition for Instrumentation and System Control*. Newnes, August 2003.
6. *** *Texas Instruments, LM35 Precision Centigrade Temperature Sensors*. Revised in October 2013. Available at: <http://www.ti.com.cn/cn/lit/ds/symlink/lm35.pdf>
7. *** *WN Software User Manual, WN-AI Voltage Input Module, WN-RLY Module, Cores*. 2004. Available at: <http://www.cores.ro/>
8. *** *ZigBee/IEEE 802.15.4 Summary by Sinem Coleri Ergen*. 2004. Available at: <http://staff.ustc.edu.cn/~ustcsse/papers/SR10.ZigBee.pdf>.