

NEW TECHNOLOGIES OF GAUGE VARIATION FOR WHEELSET VEHICLES CROSSING

P. NICOLAE¹ C. PLEŞCAN² I. SZENTES³ M. BOLÂNU⁴
C. SIMA⁵ D. MITU⁶ G. DUMITRU⁷

Abstract: *In Europe there are countries where both freight and passenger transport are affected by different gauges. Need circulation of rolling stock gauge has resulted in looking for solutions to improve various diversified systems in operation. There are two possible solutions, namely the exchange of axles (rolling element that steering bogies) or adapt them to the new gauge on the fly (during the journey without stopping the train), for rolling stock operating on different systems to track or endowment both rolling stock and infrastructure, with an automatic gauge change.*

Key words: *variable gauge, unconventional axles, suspensions, traffic safety.*

1. Introduction

The first trains offering regular passenger transport services equipped with automatic gauge change system while driving axles are TALGO trains. First, in 1969, III RD type TALGO trains (with "variable gauge") and subsequently different in various other versions of TALGO trains, equipped with a tilting box technology vehicles (circulation at high speeds).

The inclination train system is already the fifth generation, 1981. The sixth generation of such trains dating from 1988, and the seventh is viable in 2000.

These trains passed through changing track tens of thousands of times. They have been used since 1969 for international traffic and since 1992 also for domestic rail services using high-speed lines partially.

The passenger carriages type articulated trains TALGO RD are autonomous and therefore can be towed by any type of locomotive as ancillary services are supplied (insured) generating units located at the ends of the train (the second locomotive at trains traction or "end" locomotive classic, that mean pusher locomotive).

¹ Politehnica University of Bucharest & SNTFC "CFR Travellers".

² Civil Engineering Department", *Transilvania* University of Braşov.

³ SNTFC "CFR Travellers" SA.

⁴ Control Traffic Safety Department, National Railway Safety Agency.

⁵ Control Traffic Safety Department - ASFR.

⁶ Control Traffic Safety Department - ASFR.

⁷ Control Traffic Safety Department, National Railway Safety Agency.

Like all TALGO trains, their composition is varied. The wagons may be attached separately or in groups constituted various other trains. The series TALGO III RD (trains) can run at speeds up to 160 km/h in Spain and up to 140 km/h in France. The "Catalan Talgo" is a class of trains / coaches who provide transport from Barcelona to Geneva (change track and locomotives border crossing with France from Portbou) for a period of time between June 1, 1969 to May 31, 1995, (calendar date that coincides with the introduction of the transport service provided by SNCF high-speed trainsets - TGV from Geneva to Montpellier) trace which made it possible to shorten the distance to Montpellier.

The frequency of use of transport services increased immediately from two passengers on a wagon, until the supply of small vehicles daily service to Barcelona and Valencia to Montpellier in Montpellier. Moreover, two sleeping cars in composing frames / type trains TALGO RD is provide the rail passenger service at night Remote Barcelona - Paris in the period between 1974 and May 1991.

Currently, seven different systems have been developed gauge change automatically. The TALGO (Tren Articulado Ligerero Goicoechea Oriol - the slightly train / articulated frame type Goicoechea Oriol). Rafila / DB AG - Deutsche Bahn / public limited company (SA), is similar to the German system. There is a generous variety of alternative names for this acronym. Some of these refer to wheelsets adjustable depending on the gauge (GAW - Gauge Adjustable Wheelsets variable gauge wheelsets). Another explanation close relates to a switching system / automatic change of track gauge axle (ATGCS / TGC - Automatic Track Gauge Changeover System). Similarly, we can talk about a system of rehabilitation / measuring gauge

for rolling stock (RSRS - Rolling Stock Re-Gauging System), or gauge railway control system (RGAS - Rail Gauge Adjustment System) or changing or variable gauge wheelset tread, or track change depending on the track axle tread. Also SUW 2000 / bogie design PKP System is manufactured by Polish Company ZNTK Poznań for The Polish State Railways (PKP) and the BRAVA system is built by Spanish consortium CAF (Construcciones y Auxiliar de Ferrocarriles - Constructions of rolling stock and components for railways). The Japanese amending automatically gauge train wheelset is known in the literature under the name (acronym) GCT (Gauge Change Train). Furthermore, Gauge Changing Bogie - EV 90, is a gauge changeover of the bogies and in Bulgaria, The Bulgarian Automatic Gauge Changeover System - BAGCS, it is also an automatic gauge change system.

Spain has a gauge different from the European one. In addition, the decision of implementing high-speed lines, 1435 mm created an internal barrier between the conventional network and the new high speed line in the country. Spain has also developed different solutions to solve both problems.

In 2000, Spain has developed different solutions to solve both problems. Solution began with variable gauge Talgo trains in 1969, and to date, more than 260,000 trains and 325 million passengers used the trains. In 2000, the second Spanish variable gauge system developed by CAF was introduced in commercial operation.

Japan has the same internal matter between the narrow gauge (1067 mm) and track "Shinkansen" (1435 mm), and Switzerland also has two distinct types of gauge to its network of railways (1000 mm / 1435 mm). Furthermore there is a variable gauge system Polish (PKP SUW 2000), A German - track system variable

(Rafila - DB) and Bulgarian variable gauge system developed in these countries to connect rail network 1435 mm with the railway network of 1520 mm.

The fifth generation of trains TALGO is a class of trains equipped with technology for tilting boxes and variable gauge wheelset. Three of these trains were built to provide the transport of passengers on the route Madrid - Paris from May 1981 until May 1991, when this type of trains was replaced by the new class of trains TALGO - the sixth generation.

The sleeping carriages fifth generation of TALGO trains were able to run at speeds up to 160 km/h in France for a period of ten years (between 1981 and 1991) and in Spain, they were able to run at speeds up to 180 km/h, the technology of building performance of vehicles with tilting box.

Later, these trains were sixth generation passenger transport services at night different in Spain for a period of time between 1992 and 2009.

The sixth generation of TALGO passenger trains (those who only have berths) began to circulate on the national network of railways in Spain since 1988. There were technical improvements such as automatic door closing, which made them suitable for speeds of up to 200 km/h.

Trains consist of sleeping cars were put into service for movement between Barcelona and Bern in 1989 (and later between Zurich and Milan) and also generation VI trains Talgo replaced in circulation series of trains Talgo RD and fifth-generation trains TALGO trails night in Barcelona to Paris and from Madrid to Paris.

Since 2000, the consortium Talgo made a number of further technical improvements for coaches who have implemented the box tilting technology, including pressurization systems, underfloor air-conditioning systems and better sound insulation. These new wagons

(third Generation) can run at a maximum speed of 220 km/h, and their outer dimensions are identical to those in previous generations factory wagons respectively 4, 5 and 6). Passenger carriages of the current generation began circulating since the summer of 2000 between Madrid and Barcelona on conventional line. These trains are equipped with static frequency converters arranged in two vehicles by the end of the train set, which are supplied with electricity from 3000 V the engine for this purpose.

Action connection / disconnection of these vehicles from mains electricity is needed bushing sleeve handling of auxiliary circuit when changes or reverses the change gauge train locomotive. These types of trains provided rail services involving partial use of high-speed lines from 2003 until 2008. Movements such trains (trailer) was suspended in June 2009.

2. Specific Characteristics Gauges Variation Systems Automatically for Rolling Stock Axles in Movement

The system was a solution offered by the company RENFE (**R**ed **N**acional de los **F**errocarriles **E**spañoles - National Network of Spanish Railways) to prevent passengers refractor change to the Spanish border - French appliances running due gauge different from Spain, which has gauge the width of 1668 mm and other European countries that have lines with gauge 1435 mm), except by Portugal, which same type of gauge as Spain. The TALGO gauge change technology was developed smoothly and successfully since 1969, it is the newest and best technology gauge changeover "experienced" in the world. Initially was solely assigned just for the TALGO carriages of passenger trains, but its use was later extended to locomotives and locomotive end high

power (from high-speed trains type of frame, such as factories built by Alstom).

The TALGO-RD has a system of automatic change of the gauge that can be used in general bogies for locomotives engines and locomotives end high power electric trains type frame speeds. This type of bogie frame (Figure 1) is BO (ie two axles) and consists of two longitudinal beams, two beams cross at the ends and a central transverse beam (central beam).

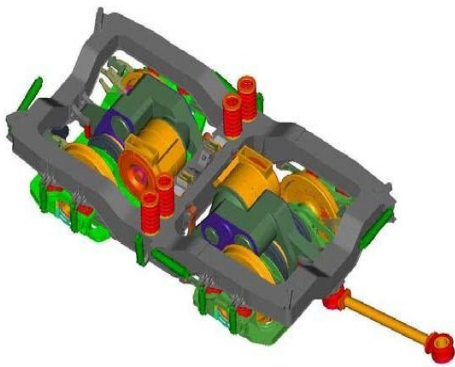

Fig. 1. The motor bogie - The TALGO system adaptability to change gauge locomotives walk

This construction provides a lightweight subset of the entire bogie and also ensures a sufficient degree of safety in areas subject to waiver requests.

In contrast to fixed-gauge bogies wheelset, this type of variation of the gauge bogie frame axle wheels is via a track width is variable, not being fixed on the axles. For freight wagons, company Talgo developed a set of wheels capable of changing the gauge bogie-fit technology "Y-25". This technology has been tested in the area Haparanda (border Swedish - Finnish) in 1997-1999 and between localities Sherbinka and Moscow (Russia) 1996. Attempts to approval by RENFE, continued and were also made during the year 1999. However, this technology is not yet in service.

O wheel sets from this type of bogies, including two sets of wheels locking

elements (Figure 2). Motor bogie, bogie freight car and passenger carriage.

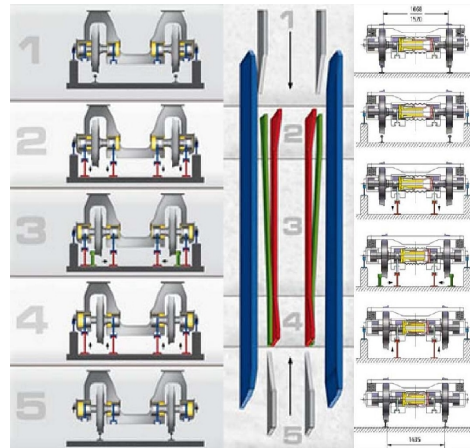

Fig. 2. The scheme sequence-specific modification technology for TALGO gauge

This type of bogie comprises a welded steel structures with four swings of support bearings (2) and four consoles bracket of the primary suspension springs (3), which are designed to transmit forces to the wheel axle (the bearing support on both sides of the bogie frame) the primary suspension and guidance to ensure the ability of the bogie via connecting rods connecting.

The bearing support swings are processed and so willing to accommodate all the components of change in the gauge axles and locking elements thereof (Figure 3).

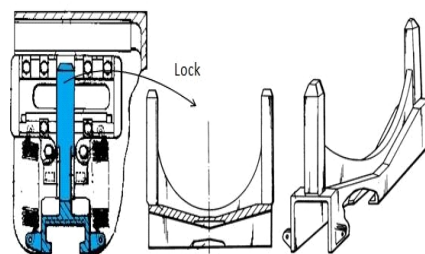

Fig. 3. The scheme of wheel set axles locking device / wheels

The axle of the gauge variation is

possible through a number two "sets" independent wheels that are coupled via a gear (gear / clutch) gear. Each set of wheels consists of single-wheel type (1), outer bearing (2) and the inner bearing (3) - Figure 4.

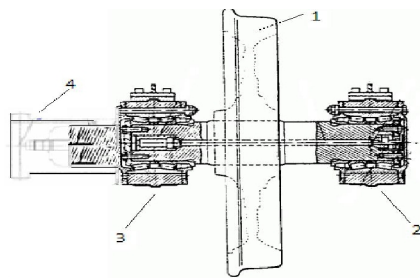

Fig. 4. a. *The monoblock elements of wheel sets: 1- Monoblock wheel set 2 - Locking system 3 - Buffer 4 - Outer bushes*

The lateral bearing surfaces are machined a stop buffer for the lock side of the wheels on the axle spindle in the wedging / clamping and transmission of lateral forces. On the outer surface of the cylindrical support mounts and lock coupling gear (gear train). This link connection is likely rigid and prevents unwanted relative rotation of the elements that must remain fixed. It allows the movements necessary for safe operation of changing the gauge (wheels) in the transverse direction (the axis of the undercarriage).

2.1. Automatic of the Gauge Change Systems of Axles for Passenger Carriages

The gearing of the wheel set for sleeping car wagons is similar to the axle bogies engines. The only difference lies in the fact that the two "sets" of wheels are coupled via a gear box of transfers. "Rodal" is a device (type gear) running for coaches (Figure 5), which was drafted / developed by the TALGO Consortium.

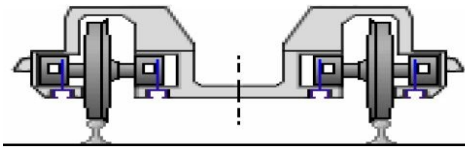

Fig. 5. *Scheme variation device gauge of axles bogies for RODAL type*

This device is used by the TALGO RD for change / variation of the gauge..

2.2. The Automatic of the Gauge Change Systems of Axles Specific Freight Wagons

The purpose of using of this equipment is to keep all parts of a standard bogie frame freight wagon and change only the axles are able to use the system variation type gauge Talgo. The design of the elements for changing track gauge of axles must be simple, so that the axles can be replaced because it have not done yet the space for the manufacture of conventional of axles of bogie frame (Figure 6). It was a bogie designed for a maximum speed of 120 km/h and a maximum axle load of 22.5 t.

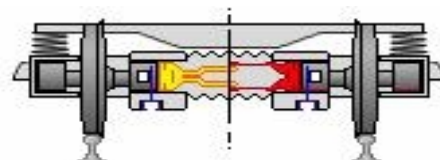

Fig. 6. *Scheme variation device gauge of axles bogies for freight wagons*

This technology has been tested, but not yet in operation.

2.3. The CET Vehicle

The CET type vehicles have a motor bogie equipped with automatic gauge change of axle. The differences between these and the bogie engine track gauge change system are represented by the bogie. The supports were removed, but

were used for engine and reduction gear, shock absorbers respectively. The remaining components are identical.

The wheelset, engine and reduction gear are not required. Instead, the clutch is fitted in the same way as if the gear reducer (Figure 7). This class of Spanish high-speed trains can travel at a maximum speed of 250 km/h (lines 1435 mm) and maximum speed of 220 km/h (to the lines with track gauge 1668 mm). This series trains began to provide rail passenger services involving partial use of high-speed lines in Spain in 2007.

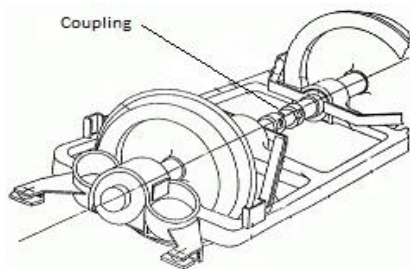

Fig. 7. The Coupling Type wheels CET

However, the set of wheels fitted equipment is identical to the bogie specific engine.

2.4. The Motor Bogies

The TRAVCA locomotives (*Tren de alta velocidad con cambio de ancho* = high speed train with variable gauge wheelset) are a prototype locomotive has two driving cabs (series production of this type of motor vehicle with just a cabin type head locomotive, being intended for use in designing tow only passenger trains high speed under the frame speed, servicing and any maintenance being performed without disengaging / posting locomotive from the train and brake thus permanently coupled to each end of the train), while having two bogies of trains that can be coupled hooked traction (Figure 8).

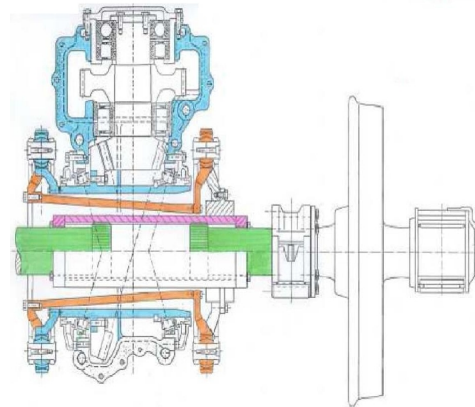

Fig. 8. The motor bogie - The TALGO system for locomotives adaptability walk gauge variation

Each axle is driven by a three-phase induction motor. That can be powered from a voltage source with a nominal value of 25 kV AC - AC or DC 3 kV DC, and has four pantographs (two for each voltage). These two units were purchased engines with four and two intermediate cars fitted with cabin hauled by the railway infrastructure manager in Spain that mean (ADIF - **A**dministrador de **I**nfraestructuras **F**errovias). ADIF made two tests gauge variation axle bogies respectively Río Adaja and route Madrid - Barcelona, which set a new world speed record in June 2002 with diesel traction (over 256 km/h).

2.5. The first Generation of Changeable and Entities in Charge of Maintenance facilities

The automatic installation for changing of the gauge consists of two rails of the running track or tracks mounted on the installation more fixed. These are permanently lubricated with grease maintained. In the process of change / modification the automatic of the gauge of axles, they are lubricated with water. The connecting element between the axles is a

hollow shaft which liaises with equipment mounted on the inner end of the "set" wheel. The TALGO train S130 series is an electric train. Is formed of two units engines (locomotives) end and a variable number of cars in the TALGO's seventh generation. The TALGO Consortium has developed a system gauge changeover of axles in 1966 allowing cross-border movement of Spanish trains in France. The common denominator of these exchangers gauge 'first generation' is that they are suitable only for The TALGO trains and are used only for towed vehicles. The locomotives do not pass through exchanger gauge for wagons and therefore they use trains must change locomotive to shift from one track to another [6].

These variable track width of the axles of vehicles used by trains covering long distances (with travel time of approximately 12 hours or more), and therefore, time for browsing facility amending the of the gauge is quite insignificant in relation to duration passengers' overall journey. Moreover, the number of kilometers traveled per day is limited (one train per direction and day for destinations Irun and three or four trains in each direction per day if the destination Portbou), which means you need fewer resources allocated for change gauge since this is a low plant utilization degree of variation gauge of axles [4].

These exchangers (installation amending of the gauge) is installed between two railway networks provided by different regulations (ADIF and RFF) which complicates customs procedures and verification of coupling and uncoupling, samples of the brake system etc. Therefore, for many years, of the gauge of axles for change affected during a trainset (without driver) was nearly half an hour, time that included all associated operations previously mentioned [1]. Since 1999, the procedures were simplified by the

possibility (thanks to the advantages of the system change gauge axles on the Madrid - Sevilla) trains to pass through the installation of checking the brakes, connected to the facility gauge changeover of axles and replacing "sample brake complete "with" verification of binding to train and locomotive brake ".

This simplified procedure facilitated deeds that trains do not have to longer stop when necessary to amend of the gauge wheelset system with changeable being used in 1981 Portbou in both directions of travel (leading to reduced the time spent changing of the gauge up to 15 minutes) and Irun in 1999 and 2003, although only North-South.

The first five generations of exchange The TALGO Track International Trains Center are built to Port Bou (Girona) in 1969, International Technology The TALGO Trains in Irún (Guipúzcoa), 1981, The TALGO technology for international trains, Aravaca (Madrid), 1967-2001, Talgo technology, for tests and maintenance, Pueblo Nuevo (Barcelona), 1969 located in Sant Andreu in 1988, Technology The TALGO maintenance / repair, and Las Matas (Madrid) 1980 Technology The TALGO maintenance / repair [1].

2.6. Second Generation of Changers and Entities in Charge of Maintenance Facilities

A second generation gauge changers emerged in response to a new need arising from the construction of the Spanish high-speed lines built with standard gauge (1435 mm). These changers gauge associated with high-speed lines to meet the criteria and stricter requirements regarding more stringent in terms of distance, must take into account that traffic everyday of these trains has a high degree together with the fact that the journey time is about 4 to 5

hours, which is important to reduce the time for the train to pass through the gauge changer. Moreover, since these trains provide frequent service, it is also important to reduce the use of resources allocated to gauge changers.

These changers second generation differ from their counterparts in the first generation in terms of how they perform change operation gauge speed and efficiency of their operation have been improved considerably by retooling 1994 - 1997 to reduce costs overall. This new operation requires the installation of air valves for front brake system (at the ends thereof), set in the first wagon of the TALGO train set.

With the posting / absolute locomotive from the train and brake, a driver got into the first car of the train set and manipulates the brake to tighten / loosen the brakes from the head of the train and stabilize the forward speed of the string parsing facility gauge change, until the cars stop at fixed depending on the length of the train, when the train brake weakens again until the first car of the train set (with modified track after riding gauge changeover system) is handled on with a speed of 10 km/h and engages the engine at standstill beyond the facility.

On this line, using gravity handling facility trains the gauge changeover is possible in the Madrid - Atocha station and Puerta Cordoba train station on the north - south direction and in the direction Majorabique station south - north.

Once exchanger gauge was built, there is need for significant changes to the rail profile. Therefore, if the apartment changers that do not offer minimum gradient for use in assisted gravity when passing through these changers (with gradients of between 4 and 6‰), the train is moving about maneuver using "special vehicles", running on the rail foot and lifts the wheels thus contributing to make the

change of the gauge passage through exchange facility.

Using these vehicles maneuvering makes it possible to reduce costs through the use of an auxiliary locomotives' handling push "is necessary, but carries increased time makes it possible to use torque handling of wagons / by train garnish gauge changeover system (2 - 3 minutes), given the fact that pushing wagons is very slowly [1].

The changers second generation gauge installed in Spain, were primarily related first high-speed lines, the construction of these changers closely linked to the construction of these new types of railway and are fitted in Madrid - Puerta de Atocha 1992, with TALGO implemented technology intended for transfer to the entity in charge of maintenance and basic commercial services. Another location is in Córdoba, 1992 - 2006, The TALGO technology for commercial services. And also in Lleida there is a location entity in charge of maintenance 2003 - 2006, The TALGO technology for commercial services.

2.7. The Third Generation of Changeable and Entities in Charge of Maintenance Facilities

The advent of the third generation of changers gauge is linked to the new high speed line Madrid - Barcelona. The project / actual design overcomes the disadvantages and limitations detected in previous generations. Both new aspects are taken into account that a new technology gauge changeover developed by CAF and the fact that both systems (both Talgo and CAF) allow vehicle engines (locomotives and EMUs / trains propelled) can pass through the system change of the gauge.

Talgo and CAF technologies developed are based on the same principles, but are not geometrically compatible. ADIF has

integrated both technologies in a single system called the double shift system used for passenger trains.

The most important innovations consist of coexistence Talgo and CAF technology platforms. The fact that the same channel maintenance (and, therefore, access to sub-assemblies of vehicles as possible on both sides of the tread in the system) is suitable for the Talgo platform, and the platform CAF, or both, it gave rise to "dual exchangers" incorporating both platforms, any of which can be placed in alignment with the rail, depending on the type of train to pass through this system to modify the of the gauge at a point [3].

A "Sunken" in areas adjacent to the rail gauge changer enables optimal functioning lubrication system and water collection and changing gravity assisted by centering the wheel in both directions.

The exchanger gauge is located in a smaller area, which facilitates the access to the downward along the rails in the direction of the gradient (slope of line) to the exchanger, allowing the train to pass through the system in both directions with the aid of gravity. This kind of gauge is "modular" and "Portal" enabling it and its systems ancillary to transport to different locations and, where appropriate, be used and investment costs can be amortized in proportion up to 80% if its parts and components are moved or used in other places. The possibility of simultaneous change of the gauge of axles for trains traveling in opposite directions [4].

3. Sequences of Operation to Changes in the Way for Gauge Axles

When the train passes over of the gauge Axle plant modification speeds between 10 and 15 km/h, the vertical load is removed from the wheels to alter its track to a set of external bearings attached to the axle shaft and then the wheels are moved / translated

in the new position of a set of built in installation guides. The same gauge change system drive axles, makes it possible to sequence specific amendment axles but also those of our engines equipping wagon bogies, this operation being carried out in five stages (Figure 9).

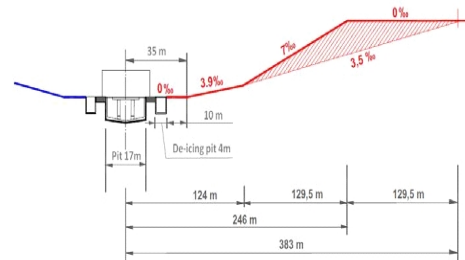

Fig. 9. *The Sunken rail profile*

In the first stage, the pads (pads) on the side of the bogie frame in contact with the outer guides installed along the sections and them. Subsequently wheels are suspended. Thereafter, in the second stage, feet facility located at the base locks that block axles are inserted into guides in the form of "T" and slides vertically in the gravitational effect that can resubmit train on. The axles are locked and free to move laterally. In stage three, the wheels of axles moving them lateral position, pushed through the system about the specific installation guides. Stage four is responsible for blocking the upward movement and fixing the wheel axle in position, while during the last stage (fifth), vehicle wheels (equipped with the system by automatic variation of the gauge of axles route) resumes again contact with the rail and resume rolling movement / running at the same time taking the vertical load of the rolling stock (vehicle in fact).

There are two types of operations in an automatic track gauge change system, according to the type of train used. The first subject towed trains (of the type The TALGO, older and without an automatic gauge changeover).

Operation amending of the gauge trains towed of axles is going through a four stage, first of them namely the arrival of the train, posting and garaging the locomotive (means towing / traction which lasts for six minutes) [7]. The second step is assigned to the transition / browsing system of changing the top level of the gauge, normally, by force of gravity. Two stages of the three minutes assigned to be traveled. The third stage is to carry-out the maneuver to attach the other end of the train locomotive. This step is designed to be implemented within four minutes. The last stage, the fourth, is designed to bind to train and locomotive brake operation should be carried out within two minutes. Total process time required reserve is 15 minutes, propelled trains (train equipped with bogie frames motors) as if new trains / technologies towing.

3.1. The Lock and Control Systems

The verification blocking / wedged correct wheelset is done in two ways respectively automatic and visual. If automatic control sensors are installed on the end shaped guides "T".

If it is found that the locks do not lock axle ensures good (wheel) or any other elements of the locking mechanism, it activates an alarm signal. In Spain, only some locations equipped with such facilities and ensure the lock control (Figure 9). As regards the visual inspection to verify the correct installation of gauge change axles is designated a qualified person [2].

3.2. Configuring of Components Automatically Adjusted to the New Railway Gauge

The brake disc is mounted to the wheel axle screwed in assembly. Therefore, it is

necessary for the system to provide the automatic replacement of the brake lining.

When the vehicle passes through the gauge changeover system, brake cylinder and air brake equipment are moved to fit and suit the way with the new gauge [2].

Replacing the brake and wheel sets is simultaneously. The parallelism remained constant between the brake disc and the brake lining, the TALGO automatic gauge exchanger systems/driving lead guides). This type of operation is faster (effective in terms of reserve time). The train is automatically switched to traction and power supply [5].

3.3. Electrical Protection of System

Electrical protection of system of the automatic of the gauge change system while driving of axles is through a system of shorting the railroad. The system provides electrical continuity between the wheels consists in ensuring contact between them by means of grounding bristles. The bristles are fixed on the intermediate element. This element is screwed onto the outer bearing bracket.

The system fulfills the requirement UIC. Electrical resistance does not exceed 0.01Ω . The protection against electric overloads and the consequences caused by currents return is possible thanks to the existence of an electrical connection between overheated axle boxes and bogie frame or frame it as is the case of the bogie type RODAL. The ground connection (earthing), allows the electrical protection of the running gear [6].

3.4. The Monitoring and Gauge Change System Maintenance and Over-Temperature Detection Level Axle Boxes

Variation monitoring system (automatic change) gauge while driving, consists of

over-temperature detection equipment on board hot axle boxes [2]. This system transmits warning and alarm messages in order to slow or stop the vehicle according to the temperature rise. Is there a temperature measurement every axle bearing. The temperature parameter they control and command to assist each bearing temperature and the difference between two consecutive axle box. As there is an axle box mounted between axles (indoors), over temperature detectors in the running (mounted raceway) are not able to measure the temperature of the axle boxes. In other words, it is only responsible for monitoring temperature - board equipment (from the endowment of locomotives) [1]. All the maintenance operations that are applied to fix of axles is carried out also and variable gauge of axles [4]. The maintenance requirements are specific the automatic of the gauge change system components.

3.5. The Defrost / Thaw Cycles System

Some of changers gauge of third-generation systems include deicing of axles / wheels rolling stock operating in cold climates or in winter season. When there is snowing on the railway line, water can enter the zones concentrates efforts on trains Talgo wheelsets and frost, thus preventing the forward movement in exchanger gauge of the train wheelset. When the train reaches the axles frozen at a gauge changeover system of axles first or second generation, helping nozzle type "Kärcher" is used manually to spray pressurized hot water frozen on the running of the trains arrived at the facility, but can take up to five hours to thaws whole trainset. To carry out this operation quickly review channels were equipped with automatic defrosting system which sprays appropriate areas with hot water

under pressure in a more concentrated on the sides of exchangers, which are considered necessary [5].

The capacity defroster for being established (and thus to determine the time required to complete the process itself) depends on the schedule anticipated movement of trains (of graphics and programs movement of trains) and the probability for trains to arrive gauge changeover installations of axles with this problem. Exchanger gauge at Plasencia De Jalon was the first facility thaw cycles / defroster which was installed in this location, operated bilateral (on both sides of the train / vehicle) and this type of facility defroster was used and implemented the installation gauge changeover axles from Roda, Antequera, Valladolid, Valdestillas, Lérida and Zaragoza Delicias (Spain). The range of ambient temperatures at which operation is designed to function wheelset (wheel): from 25° C up to +50° C.

4. Conclusions

The TALGO gauge change technology was developed smoothly and successfully since 1969, it is the newest and best technology gauge change "experienced" in the world. Originally it was solely for TALGO carriages of passenger trains, but its use was later extended to locomotives and locomotive end high power (from high-speed trains type of frame, such as factories built by Alstom).

Spain has a gauge different from the European one. In addition, the decision of implementing high-speed lines, 1435 mm created an internal barrier between the conventional network and the new high speed line in the country. In 2000, Spain has developed different solutions to solve both problems.

Japan has the same internal matter between the narrow gauge (1067mm) and track "Shinkansen" (1435 mm), and Switzerland also has two distinct types of gauge to its network of railways (1000 mm / 1435 mm).

Acknowledgements

The work has been funded by the Sectorial Operational Programme Human Resources Development 2007-2013 of the Ministry of European Funds through the Financial Agreement POSDRU / 159 / 1.5 / S / 132395.

References

1. Álvarez, A. G. - *Automatic Track Gauge Changeover for Trains in Spain*, September 2010.
2. Dumitru, G. *Considerații asupra unor aspecte legate de dinamica vehiculelor motoare de cale ferată (Considerations on some aspects related to dynamic of railway vehicle engine)*, MID-CF Magazine, no. 1/2008.
3. Garcia, E. - *Solución Talgo para sistemas de cambio de ancho en ejes*. First European Forum on Railway Running Gears, June 2011.
4. Geissler, J. H. - *Results of Feasibility Study "Automatic Gauge Changeover Systems"*, October 2009.
5. Hiroumi, S. *Railway Technology in Japan, Challenges and Strategies*, 2003.
6. Iglesias, I.J. - *The UNICHANGER Project: A unique approach to eliminate rail frontiers due to the variable gauge*, May 2011.
7. Kazuhiro, O. - *Developing a Gauge Changing EMU*, Railway Technical Research Institute, 2001.