

# THE INFLUENCE OF THE BUILD ORIENTATION ON THE TENSILE STRENGTH AND THE HARDNESS OF THE POLYAMIDE PARTS MADE BY SELECTIVE LASER SINTERING TECHNOLOGY

T. BEDŐ<sup>1</sup> S.I. MUNTEANU<sup>1</sup> T. PENG<sup>2</sup> M.A. POP<sup>1</sup>  
C. GABOR<sup>1</sup> D. CRISTEA<sup>1</sup> D. MUNTEANU<sup>1</sup>

**Abstract:** *Developing products using AM technology results in reduced material consumption, as processing additions are much smaller or even totally absent unlike conventional subtraction technologies. The present article describes the influence of the part build orientation (construction angle in relation to the horizontal) on the tensile strength and hardness of the polyamide parts (DuraForm PA Plastic) obtained through Selective Laser Sintering (SLS) technology. The print orientation of the part has a significant influence on both the mechanical properties and the efficiency of using the machine's building volume.*

**Key words:** *selective laser sintering, build orientation, tensile strength, Shore hardness.*

## 1. Introduction

The additive manufacturing (AM) technology has now entered into almost all branches of industrial production as well as spheres of activity in which, until recently, it was considered improbably, like medical engineering, dental technique or biomaterials. After the emergence of the first commercial equipment in 1986, AM technology quickly became the preferred technology for producing high precision parts with complex geometry directly from 3D computer-aided design (CAD) drawings. Essentially, AM technology is based on the final product by depositing successive layers of material starting from a 3D CAD drawing. More and more researchers, members of the academic community or reputed research institutes around the world [1, 2, 3, 7, 17] are devoted to studying the parameters that influence the results of this technology that will certainly become of everyday use in the future industry.

The time consumed between design and prototype or so-called *zero series* manufacturing drops considerably, which is why technology was originally developed as

---

<sup>1</sup> Materials Science Dept., *Transilvania* University of Braşov.

<sup>2</sup> School of Mechanical Engineering, Shenyang Jianzhu University, Shenyang, China.

*rapid prototyping technology*. Also, obtaining the product using this technology, automatically translates to reduced material consumption, since processing additions are much lower or even totally absent, as opposed to classical subtraction technologies. In other words, AM processes in general and Powder Bed Fusion (PBF) specifically, have a big potential to simplify and lower the cost of complex manufacturing.

Syed Tofail et al. [20] present some incontestable advantages of AM technology: direct translation of design to component; product realization with no additional tooling or manufacturing cost; making products with geometry as complex as possible; flexible and lightweight component manufacturing with hollow or lattice structures; the possibility of obtaining the products in their final or near final form; excellent scalability etc.

The advantages and so far evolution of AM are sufficient reasons for Ugur Dilberoglu et al. [4] to foresee that AM technology will play a particularly important role in the so-called "era of Industry 4.0" in which the intelligent factories will be determinant - Figure 1.

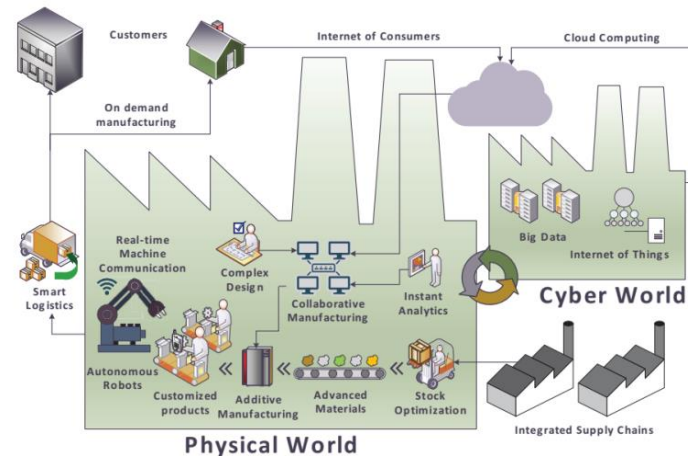

Fig. 1. Schematic presentation of smart factories with general properties required in Industry 4.0. [4]

The term AM includes a number of subgroups such as 3D printing, Rapid Prototyping, Direct Digital Manufacturing, Layered Manufacturing and Additive Manufacturing.

The International Organization for Standardization (ISO)/American Society for Testing and Materials (ASTM) 52900:2015 standard classify standard AM processes into seven categories:

- 1 - binder jetting (BJ);
- 2 - directed energy deposition (DED);
- 3 - material extrusion (ME);
- 4 - material jetting (MJ);
- 5 - powder bed fusion (PBF);
- 6 - sheet lamination (SL); and
- 7 - vat photopolymerization (VP).

If the specific case of PBF, the main characteristics, principles, materials, advantages, disadvantages and workspace dimensions are shown in Table 1 [20].

Main characteristics of PBF process [20]

Table 1

ASTM category	Basic principle	Example technology	Advantages	Disadvantages	Materials	Build volume [mm x mm x mm]
PBF	Thermal energy fuses a small region of the powder bed of the build material	Electron beam melting (EBM) Direct Metal Laser Sintering (DMLS) Selective Laser Sintering/Melting (SLS/SLM)	Relatively inexpensive Small footprint Powder bed acts as an integrated support structure Large range of material options	Relatively slow Lack of structural integrity Size limitations High power required Finish depends on precursor powder size	Metals Ceramics Polymers Composites Hybrid	Small X = 200-300 Y = 200-300 Z = 200-350

In this article the influence of the print orientation on the part's properties was studied for samples manufactured by Selective Laser Sintering (SLS) technique (schematic presentation of the process is shown in Figure 2).

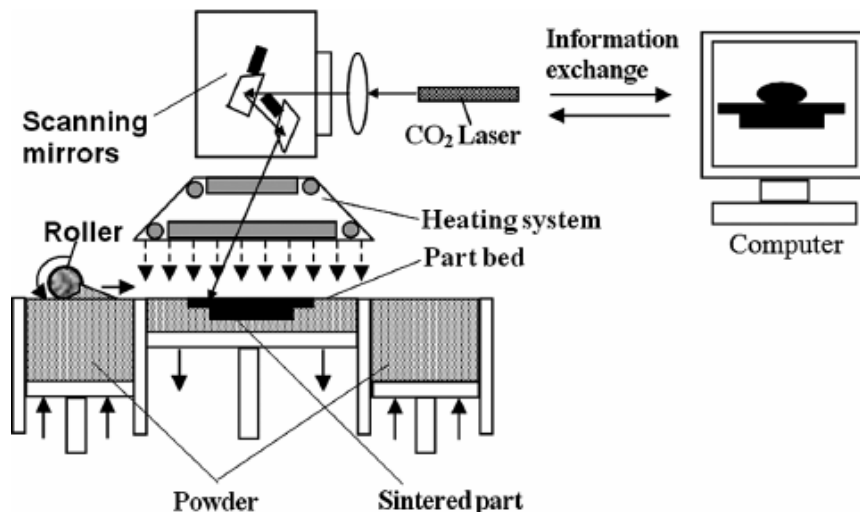
Fig. 2. *The selective laser sintering -SLS - process [7]*

There is almost no branch of activity where the use of plastic materials and products of such materials is lacking. The virtually limitless possibilities offered by the SLS process, as well as the multitude of equipment using this process, have made it the object of numerous studies and researches [8, 11, 16, 18, 21]. However, the process is suitable for a number of other materials such as metallic, ceramic etc. [6].

In addition to the undeniable advantage of ease of use, the virtually limitless complexity of the shape of the finished parts and the wide variety of materials that can be worked, the choice of this technology is conditioned by the final product characteristics being achieved. Among other factors of influence, these properties are based on the part build orientation when printed.

A number of articles in dedicated journals address the subject of the influence of part build orientation in AM technology [5, 9, 10, 12, 13, 14, 15, 19, 22] on its final characteristics.

The present article describes the influence of the part build orientation (construction angle in relation to the horizontal), of the SLS technology on the tensile strength and hardness of the polyamide parts (DuraForm PA Plastic).

## 2. Materials and Methods

The specimens used in this research were made of polyamide - DuraForm PA Plastic - supplied by 3D Systems. Main characteristics of this polyamide, according to the manufacturer [23] are presented in the Table 2.

*DuraForm PA Plastic: main properties*

Table 2

Measurement	Condition	Values
Specific gravity	ASTM D792	1 g/cm <sup>3</sup>
Mechanical Properties		
Tensile Strength, Ultimate	ASTM D 638	43 MPa
Tensile Modulus	ASTM D 638	1586 MPa
Elongation at Break	ASTM D 638	14%
Flexural Strength, Ultimate	ASTM D 790	48 MPa
Flexural Modulus	ASTM D 790	1387 MPa
Hardness, Shore D	ASTM D2240	73
Thermal Properties		
Specific Heat Capacity	ASTM E1269	1.64 J/(g °C)
Thermal Conductivity	ASTM E1225	0.70 W/(m K)

The specimens were produced on a Selective Laser Sintering 3D System SPRO 60 SD.

The tension tests were carried out on a universal mechanical testing machine of WDW-150 S type.

The hardness was measured with a Souter Shore hardness tester, being established as an average of 6 measurements per sample.

Three types of test specimens were used - edge, flat and cylindrical, printed in various positions (Figure 3) with the following  $\alpha$  construction angle values: 0, 30, 45, 60 and 90 degrees, the measurement being made relative to the build base (xOy plane).

The dimensions, in mm, of the specimens are shown in Figure 4.

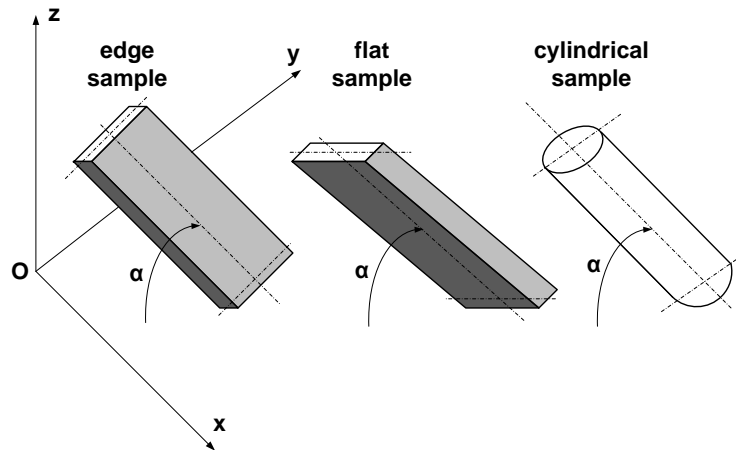

Fig. 3. Printing position of the samples

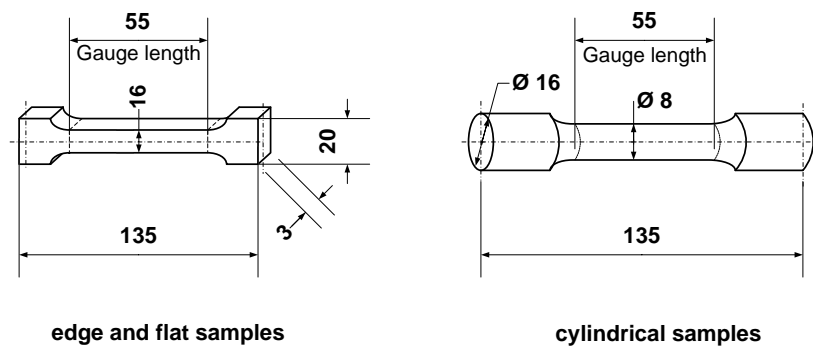

Fig. 4. Samples dimensions

All samples were printed in a machine cycle using a 14W laser power and a 0.1 mm powder layer thickness. For each type of specimen and each value of the construction angle 5 specimens were made, the final values of the measurements being the arithmetic mean of the five values.

### 3. Results and Discussions

The results of the tension and the hardness tests for the analyzed specimens are presented in the Table 3. All values presented are the arithmetic mean of the measurements made (5 for traction tests and 6 for hardness).

The variation of the analyzed properties by the angle of construction ( $\alpha$ ) for the three types of samples is shown in Figures 5, 6 and 7.

If we analyze the principle of the SLS process (manufacturing of the final product in the successive layers), we can assimilate the final product with a *sandwich*-type composite in which all the layers are made of the same material. Depending on the alpha angle of construction the distribution of the layers in the sample body is as presented in Figure 8 (with a similar situation for the cylindrical samples).

Results of the tension and the hardness tests

Table 3

Angle [degree]	0		30		45		60		90	
Properties	Rm* [MPa]	hardness, Shore D	Rm [MPa]	hardness, Shore D	Rm [MPa]	hardness, Shore D	Rm [MPa]	hardness, Shore D	Rm [MPa]	hardness, Shore D
Edge	43.33	72.42	35.67	71.28	41	74.96	39.33	69.64	36.67	74.30
Flat	41.67	73.06	36.50	72.82	43.80	74.96	41.50	76.63	37.67	74.45
Cylindrical	60	74.80	62	72.90	47.73	72.22	40	74.56	53	73.66

\*Rm - ultimate tensile strength

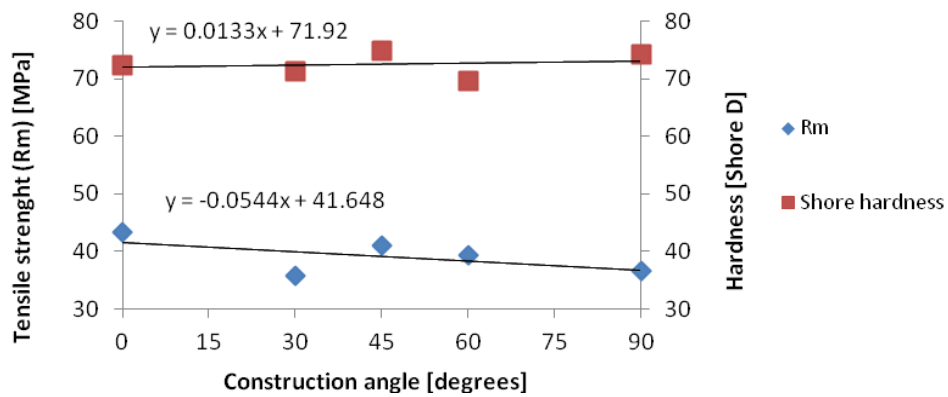
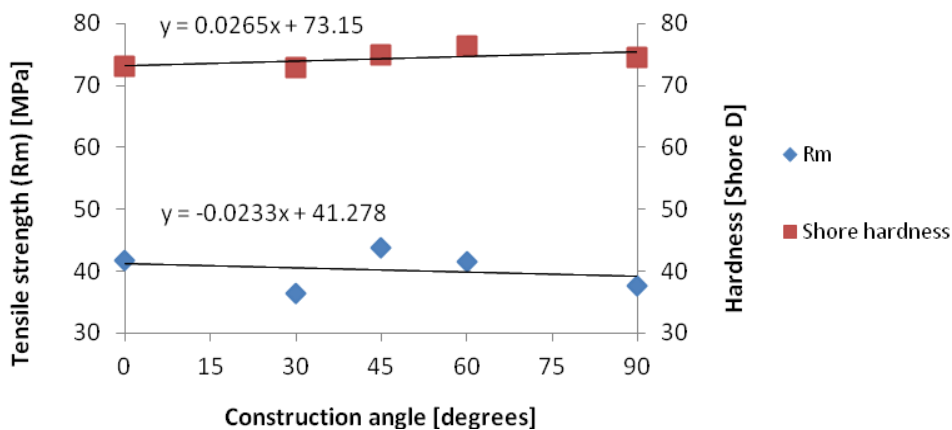
Fig. 5. The variation of tensile strength and Shore hardness by  $\alpha$  for the edge sampleFig. 6. The variation of tensile strength and Shore hardness by  $\alpha$  for the flat sample

Taking into account that, in the case of tensile test, the force acts along the longitudinal axis of the sample, it is clear that the  $\alpha = 0^\circ$  situation is the most favorable and the  $\alpha = 90^\circ$  situation is the least convenient. This is also confirmed by the tensile strength values variation tendency for all three sample types: edge, flat and cylindrical - Figure 9.

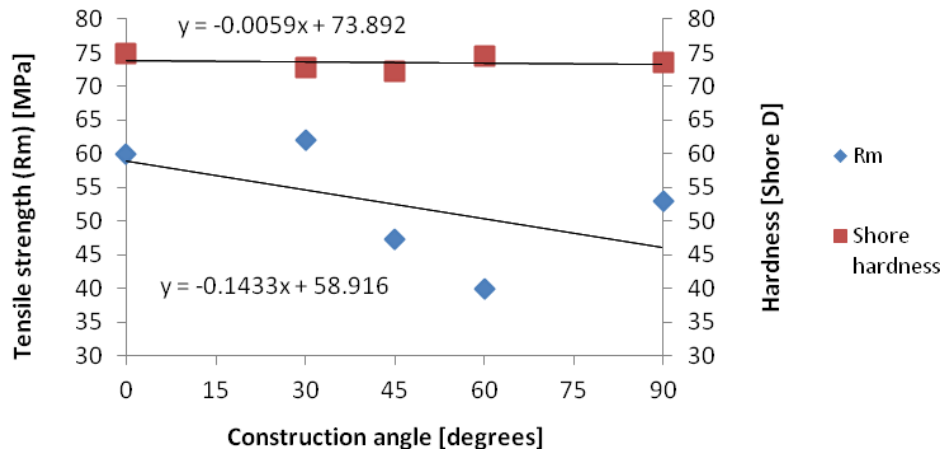

Fig. 7. *The variation of tensile strength and Shore hardness by  $\alpha$  for the cylindrical sample*

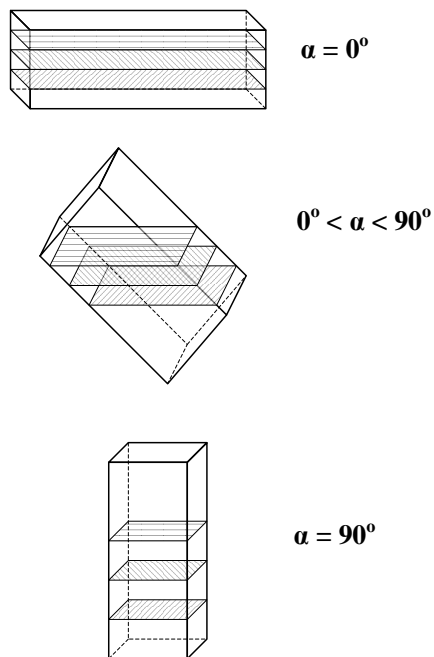

Fig. 8. *The distribution of the layers in the sample body by construction angle*

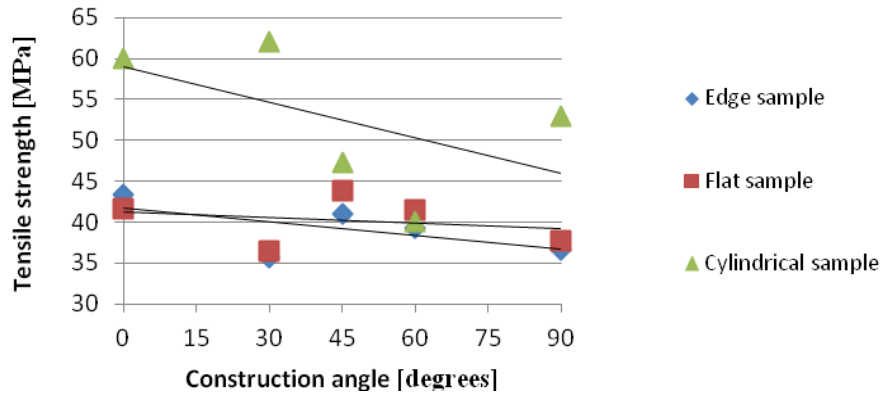

Fig. 9. *Tendency to vary of the tensile strength values*

In the case of hardness, the situation is different since the samples built at  $\alpha = 90^\circ$  are practically tested on one edge of the layer and thus the maximum value is obtained - for the edge and flat samples. For cylindrical samples the hardness values maintain a relatively constant evolution due to the specific shape of the surface with significantly less influence on the test results (Figure 10).

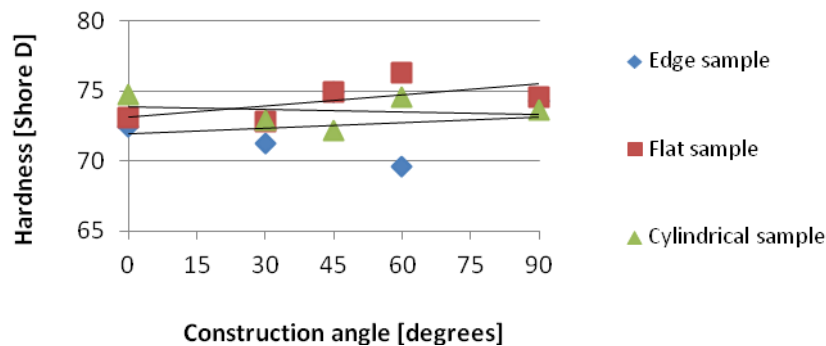

Fig. 10. *Tendency to vary of the Shore hardness values*

#### 4. Conclusions

The quality of SLS pieces is influenced by the build orientation of the part to be printed.

The research presented in this article demonstrates that tensile strength decreases as the construction angle increases from the base of construction. The minimum value of the tensile strength is obtained in the vertical position. As a result, in the case of traction parts, they will be aligned with the tensile request plane parallel to the building plane.

The hardness of the printed parts increases with the construction angle, therefore obtaining parts with hard surfaces is conditioned by printing them in the upright position.



It should also be borne in mind that the build orientation of the piece at print has an influence on the efficient use of the building volume of the machine.

The engineer designing the technology, using the SLS, will consider all these requirements and will choose an optimal settlement.

### Acknowledgements

This work was supported by a grant of the Romanian National Authority for Scientific Research and Innovation, CNCS/CCCDI - UEFISCDI, project number PN-III-P3-3.6-H2020-2016-0077, within PNCDI III.

We hereby acknowledge the structural founds project PRO-DD (POS-CCE, O.2.2.1., ID 123, SMIS 2637, ctr. No 11/2009) for providing the infrastructure used in this work.

### References

1. Bahnini, I., Rivette, M., et al.: *Additive Manufacturing Technology: The Status, Applications and Prospects*. In: The International Journal of Advanced Manufacturing Technology **97** (2018), p. 147-161.
2. Bikas, H., Stavropoulos, P., Chryssolouris, G.: *Additive Manufacturing Methods and Modelling Approaches: A Critical Review*. In: Int. J. Adv. Manuf. Technol. **83** (2016) p. 389-405.
3. Chen, L., He, Y., et al.: *The Research Status and Development Trend of Additive Manufacturing Technology*. In: Int. J. Adv. Manuf. Technol. **89** (2017), p. 3651-3660.
4. Dilberoglu, U.M., Gharehpapagh, B., et al.: *The Role of Additive Manufacturing in the Era of Industry 4.0*. In: Procedia Manufacturing **11** (2017), p. 545-554.
5. Eiliat, H., Urbanic, J.: *Determining the Relationships between the Build Orientation, Process Parameters and Voids in Additive Manufacturing Material Extrusion Processes*. In: The International Journal of Advanced Manufacturing Technology, sept. 2018.
6. Fayed, E.M., Elmesalamy, A.S., et al.: *Characterization of Direct Selective Laser Sintering of Alumina*. In: Int. J. Adv. Manuf. Technol. **94** (2018), p. 2333-2341, DOI 10.1007/s00170-017-0981-y.
7. Guo, N., Leu, M.C.: *Additive Manufacturing: Technology, Applications and Research Needs*. In: Front. Mech. Eng. **8 (3)** (2013), p. 215-243.
8. Hettesheimer, T., Hirzel, S., Roß, H.B.: *Energy Savings through Additive Manufacturing: An Analysis of Selective Laser Sintering for Automotive and Aircraft Components*. In: Energy Efficiency **11** (2018), p. 1227-1245.
9. Jaiswal, P., Patel, J., Rai, R.: *Build Orientation Optimization for Additive Manufacturing of Functionally Graded Material Objects*. In: The International Journal of Advanced Manufacturing Technology **96** (2018), p. 223-235.
10. Khodaygan, S., Golmohammadi, A.H.: *Multi-Criteria Optimization of the Part Build Orientation (PBO) through a Combined Meta-Modeling/NSGAII/TOPSIS Method for Additive Manufacturing Processes*. In: International Journal on Interactive Design and Manufacturing (IJIDeM) **12** (2018), p. 1071-1085.

11. Kumar, S.: *Selective Laser Sintering: A Qualitative and Objective Approach*. In: JOM, October 2003, p. 43-47.
12. Langelaar, M.: *Combined Optimization of Part Topology, Support Structure Layout and Build Orientation for Additive Manufacturing*. In: Structural and Multidisciplinary Optimization **57** (2018), p. 1985-2004.
13. Morgan, H.D., Cherry, J.A., et al.: *Part Orientation Optimisation for the Additive Layer Manufacture of Metal Components*. In: Int. J. Adv. Manuf. Technol. **86** (2016), p. 1679-1687.
14. Olivier, D., Travieso-Rodriguez, J.A., et al.: *Influence of Building Orientation on the Flexural Strength of Laminated Object Manufacturing Specimens*. In: Journal of Mechanical Science and Technology **31 (1)** (2017), p. 133-139.
15. Pereira, S., Vaz, A.I.F., Vicente, L.N.: *On the Optimal Object Orientation in Additive Manufacturing*. In: The International Journal of Advanced Manufacturing Technology **98** (2018), p. 1685-1694.
16. Ragulya, A.V.: *Selective Laser Sintering. I. Principles, Continual Model*. In: Powder Metallurgy and Metal Ceramics **37** (1998), Nos. 7-8.
17. Salonitis, K.: *Design for Additive Manufacturing Based on the Axiomatic Design Method*. In: Int. J. Adv. Manuf. Technol. **87** (2016), p. 989-996.
18. Singh, S., Sachdeva, A., Sharma, V.S.: *Optimization of Selective Laser Sintering Process Parameters to Achieve the Maximum Density and Hardness in Polyamide Parts*. In: Prog. Addit. Manuf. **2** (2017), p. 19-30.
19. Strano, G., Hao, L., et al.: *A New Approach to the Design and Optimisation of Support Structures in Additive Manufacturing*. In: Int. J. Adv. Manuf. Technol. **66** (2013), p. 1247-1254.
20. Tofail, S.A.M., Koumoulos, E.P., et al.: *Additive Manufacturing: Scientific and Technological Challenges, Market Uptake and Opportunities*. In: Materials Today **21(1)** (2018) January/February, p. 22-37.
21. Wei, Q., Wang, R., et al.: *Effects of Process Parameters on Dimensional Precision and Tensile Strength of Wax Patterns for Investment Casting by Selective Laser Sintering*. In: China Foundry: Research & Development **15 (4)** (2018), p. 299-306.
22. Zhang, Y., Bernard, A., et al.: *Build Orientation Optimization for Multi-Part Production in Additive Manufacturing*. In: J. Intell. Manuf. **28** (2017), p. 1393-1407, DOI 10.1007/s10845-015-1057-1.
23. [https://www.3dsystems.com/sites/default/files/2017-03/3D-Systems\\_DuraForm\\_PA\\_DATASHEET\\_A4\\_US\\_2017.03.22\\_WEB.pdf](https://www.3dsystems.com/sites/default/files/2017-03/3D-Systems_DuraForm_PA_DATASHEET_A4_US_2017.03.22_WEB.pdf). Accessed 12.10.2018.
24. [https://www.researchgate.net/figure/Schematic-illustration-of-the-selective-laser-sintering-SLS-process\\_fig1\\_262698615](https://www.researchgate.net/figure/Schematic-illustration-of-the-selective-laser-sintering-SLS-process_fig1_262698615). Accessed 10.10.2018.